

E.M. “CLÉLIA CARMELO DA SILVA”

SEGUNDO BIMESTRE

ATIVIDADE Nº 05

ATIVIDADES REFERENTES AOS DIAS: 11, 12, 13, 14, 17, 18, 19, 20, 21, 24, 25, 26, 27, 28, 31 DE MAIO.



1º ANO C

NOME:

A PRÓXIMA RETIRADA DE ATIVIDADES E DEVOLUÇÃO DAS ANTERIORES SERÁ NO DIA: 08/06/2021.

PROFª DIANA DA ENCARNAÇÃO AMARO SOARES

PORTUGUÊS

VAMOS RELEMBRAR O NOME E O SOM DAS LETRINHAS DO ALFABETO?
ACOMPANHE O VÍDEO QUE A PROFESSORA IRÁ ENVIAR NO NOSSO GRUPO
DO WATSAPP E VAMOS TREINAR!

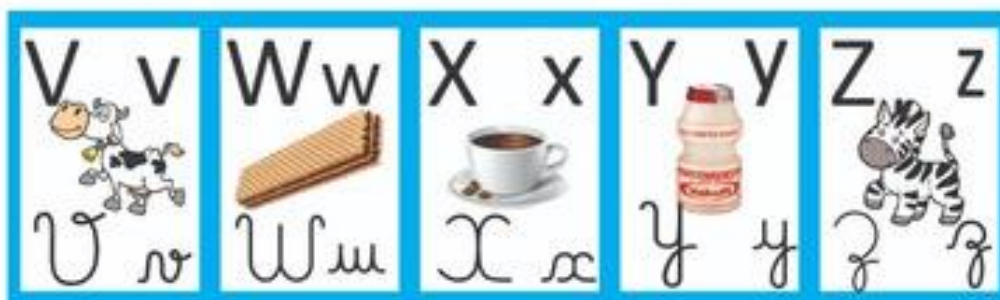
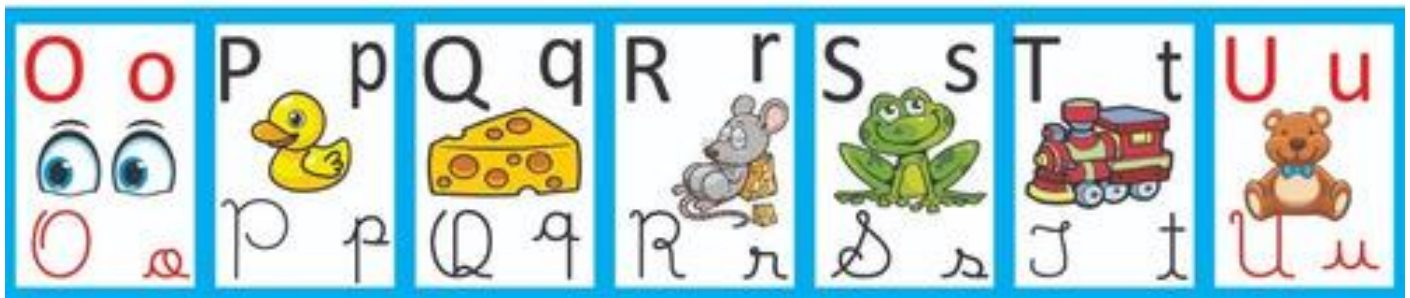
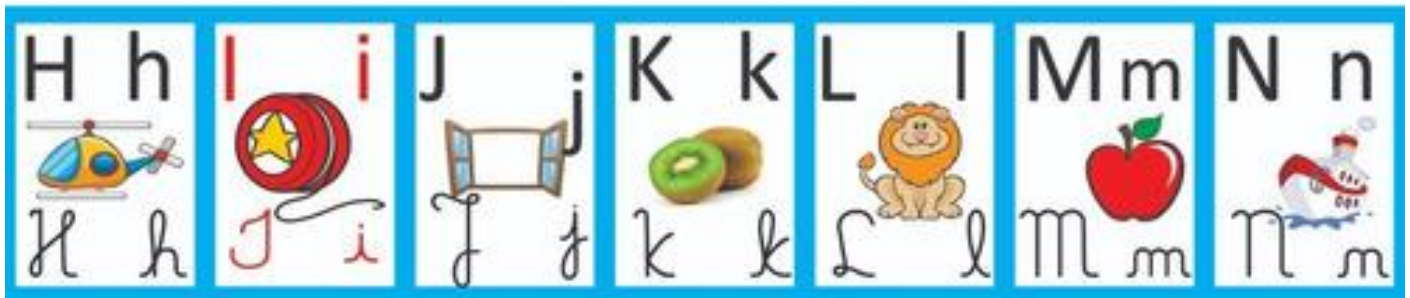
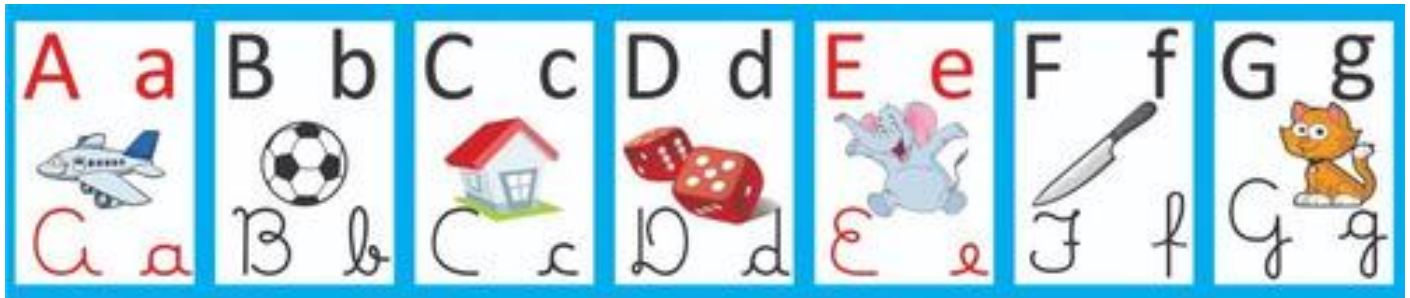

https://http2.mlstatic.com/D_NQ_NP_913369-MLB40419035181_012020-O.jpg

1) O TRENZINHO DA MÔNICA JÁ VAI PARTIR, ANTES, ESCREVA A LETRA INICIAL DE CADA DESENHO NOS VAGÕES.

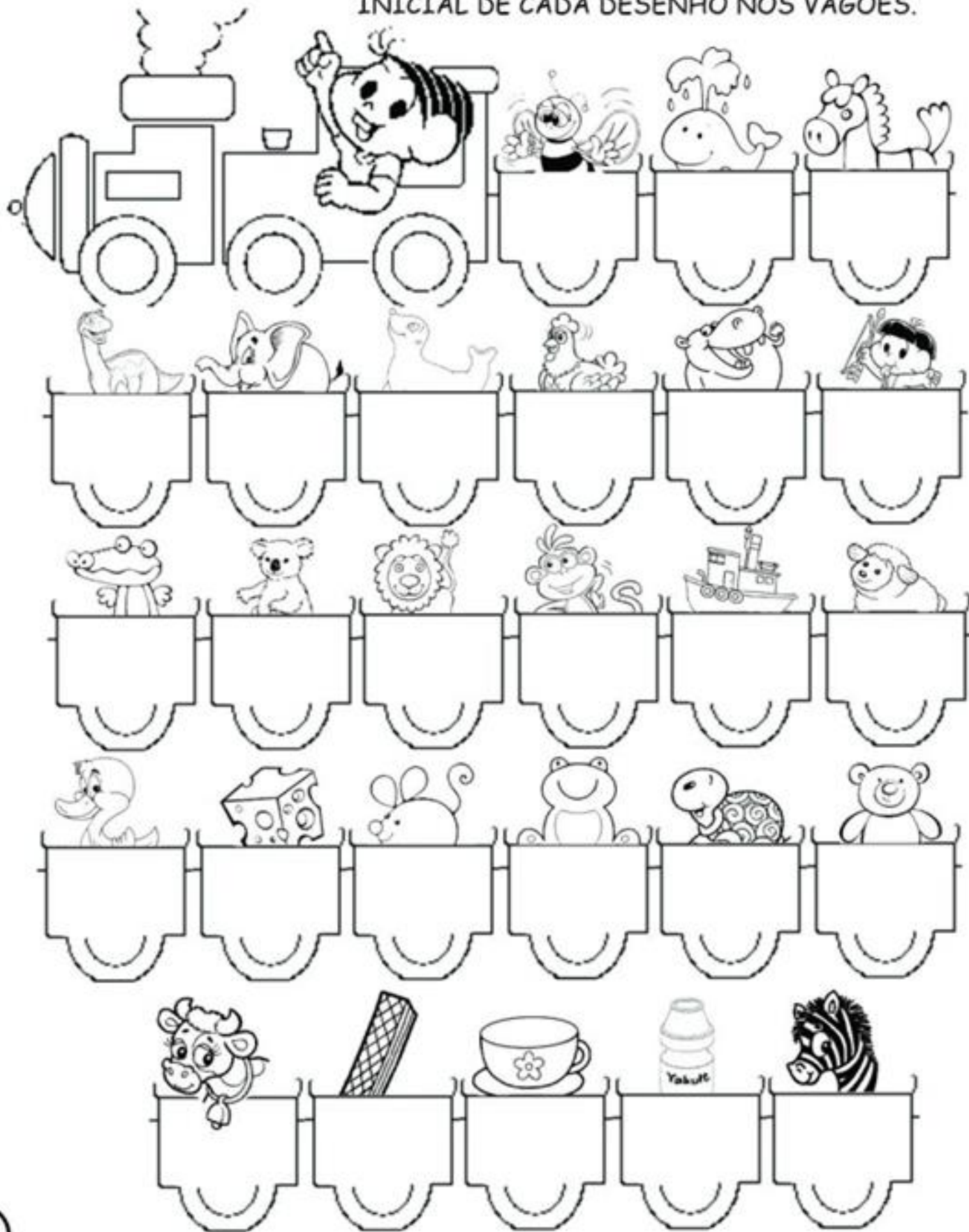

MATEMÁTICA

TRABALHANDO O CALENDÁRIO

1. PINTE A DATA DE HOJE.



DIA DA SEMANA

DOMINGO	SEGUNDA-FEIRA	TERÇA-FEIRA
QUARTA-FEIRA	QUINTA-FEIRA	SEXTA-FEIRA
SÁBADO		

DIA DO MÊS

1	2	3	4	5	6	7	8	9	10	11
12	13	14	15	16	17	18	19	20	21	22
24	25	26	27	28	29	30	31			

MÊS DO ANO

JANEIRO	FEVEREIRO	MARÇO	ABRIL
MAIO	JUNHO	JULHO	AGOSTO
SETEMBRO	OUTUBRO	NOVEMBRO	DEZEMBRO

GRÁFICOS.

CADA QUADRINHO PINTADO REPRESENTA UM BISCOITO QUE GIOVANA COMEU DURANTE A SEMANA.

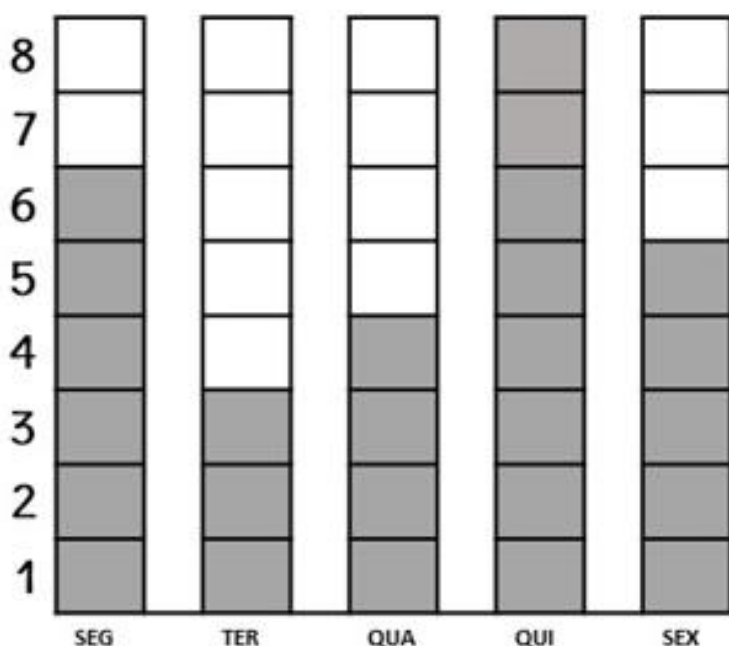

1- QUANTOS BISCOITOS ELA COMEU...

SEGUNDA-FEIRA

TERÇA-FEIRA

QUARTA-FEIRA

QUINTA-FEIRA

SEXTA-FEIRA

2- QUAL DIA DA SEMANA ELA COMEU MAIS BISCOITOS?

<https://israelakotona.blogspot.com/>

RESOLVA AS ADIÇÕES ABAIXO:



$5+2=$



$7+1=$



$3+3=$



$1+4=$



$4+5=$



$8+2=$



$2+3=$



$1+6=$



$6+4=$



$9+1=$



$7+2=$



$2+6=$

CIÊNCIAS



CABEÇA, OMBRO, JOELHO E PÉ. JOELHO E PÉ
CABEÇA, OMBRO, JOELHO E PÉ. JOELHO E PÉ

OLHOS, OUVIDOS, BOCA E NARIZ
CABEÇA, OMBRO, JOELHO E PÉ. JOELHO E PÉ

OBS: ACOMPANHE O VÍDEO NO WATSAPP E VAMOS CANTAR?
RECORTE E COLE AS PARTES DO CORPO NO LUGAR CORRETO.

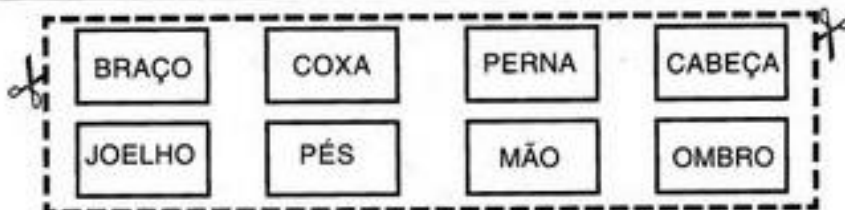
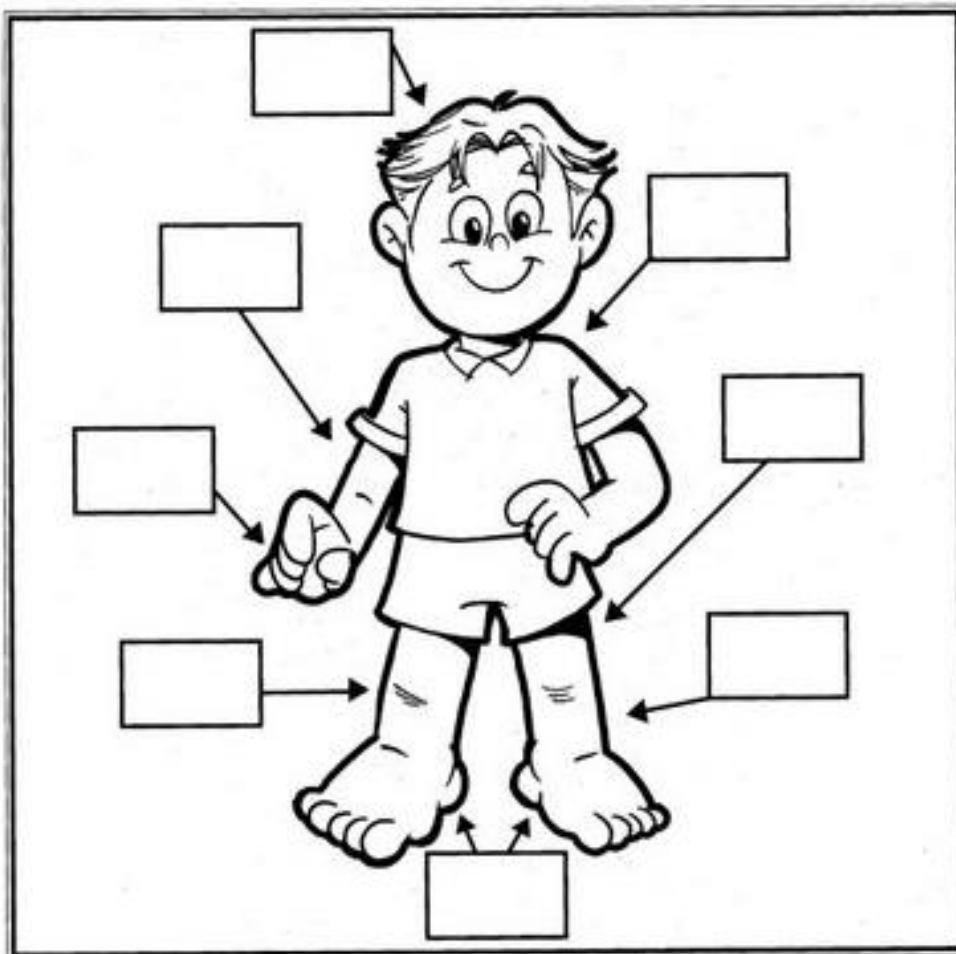

<https://talentospedagogicos.blogspot.com/>

ONDE USAMOS?

LIGUE OS OBJETOS ÀS PARTES DO CORPO NAS QUAIS ELES SÃO USADOS.



CABEÇA

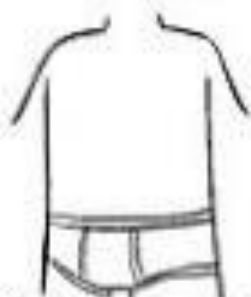

TRONCO



MEMBROS
SUPERIORES



MEMBROS
INFERIORES



BLUSA



TÊNIS



BONÉ



RELÓGIO

LEIA O TEXTO:

A LAGARTA LILA

LILA É UMA LAGARTA
QUE MORA LÁ NO IPÊ
QUANDO SENTE MUITA FOME
PICA A FOLHA PRA COMER

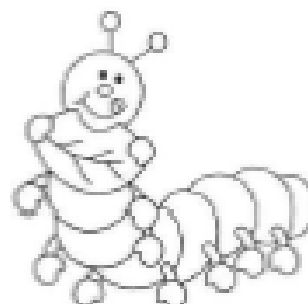

GRAÇA BOQUET

1. LILA É UMA:

2. ELA MORA NO:

3. O QUE LILA FAZ QUANDO SENTE FOME:

() COME FOLHA

() COME GRÃOS

() COME FLORES

4. OBSERVE A PALAVRA ABAIXO:

LAGARTA

A) A PRIMEIRA LETRA É: _____

B) A ÚLTIMA LETRA É: _____

C) A PRIMEIRA SÍLABA É: _____

D) A ÚLTIMA SÍLABA É: _____

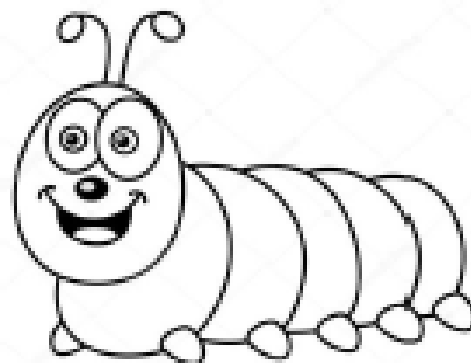

HOJE VAMOS CONHECER UM POUCO MAIS A LETRA L.

LA LE LI LO LU

1-PINTE CADA DESENHO DE ACORDO COM A COR INDICADA PELA LEGENDA DE SÍLABAS.

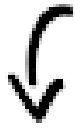

LA

AZUL

LE

VERDE

LI

VERMELHO

LO

AMARELO

LU

LILÁS

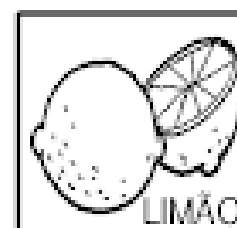
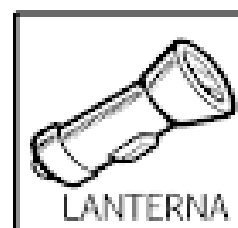
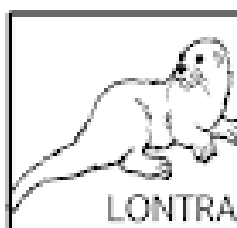
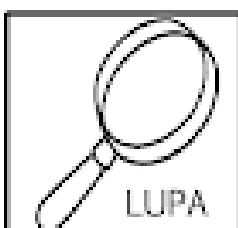
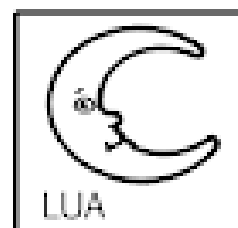
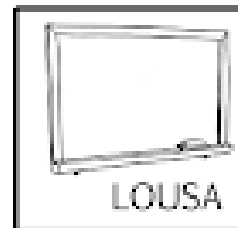
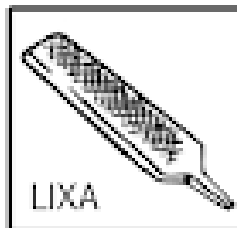
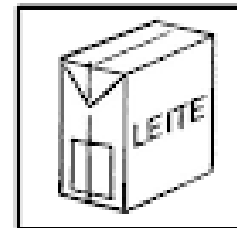
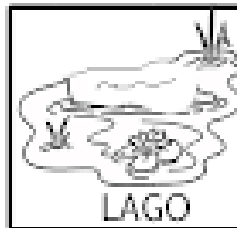
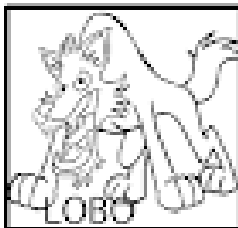
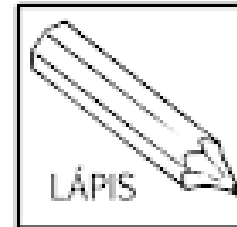
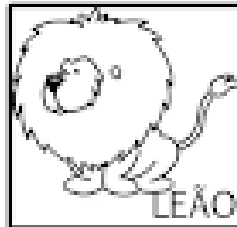
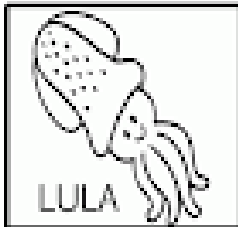

HISTÓRIA E GEOGRAFIA

1 - CIRCULE AS FIGURAS QUE INDICAM CRIANÇAS BRINCANDO NUM ESPAÇO FORA DE CASA. EM SEGUIDA FAÇA UM X NO CÍRCULO QUE REPRESENTA O QUE VOCÊ MAIS GOSTA DE FAZER.



ONDE EU MORO?

1- DESENHE O LUGAR ONDE VOCÊ MORA COM SUA RUA, SUA CASA...

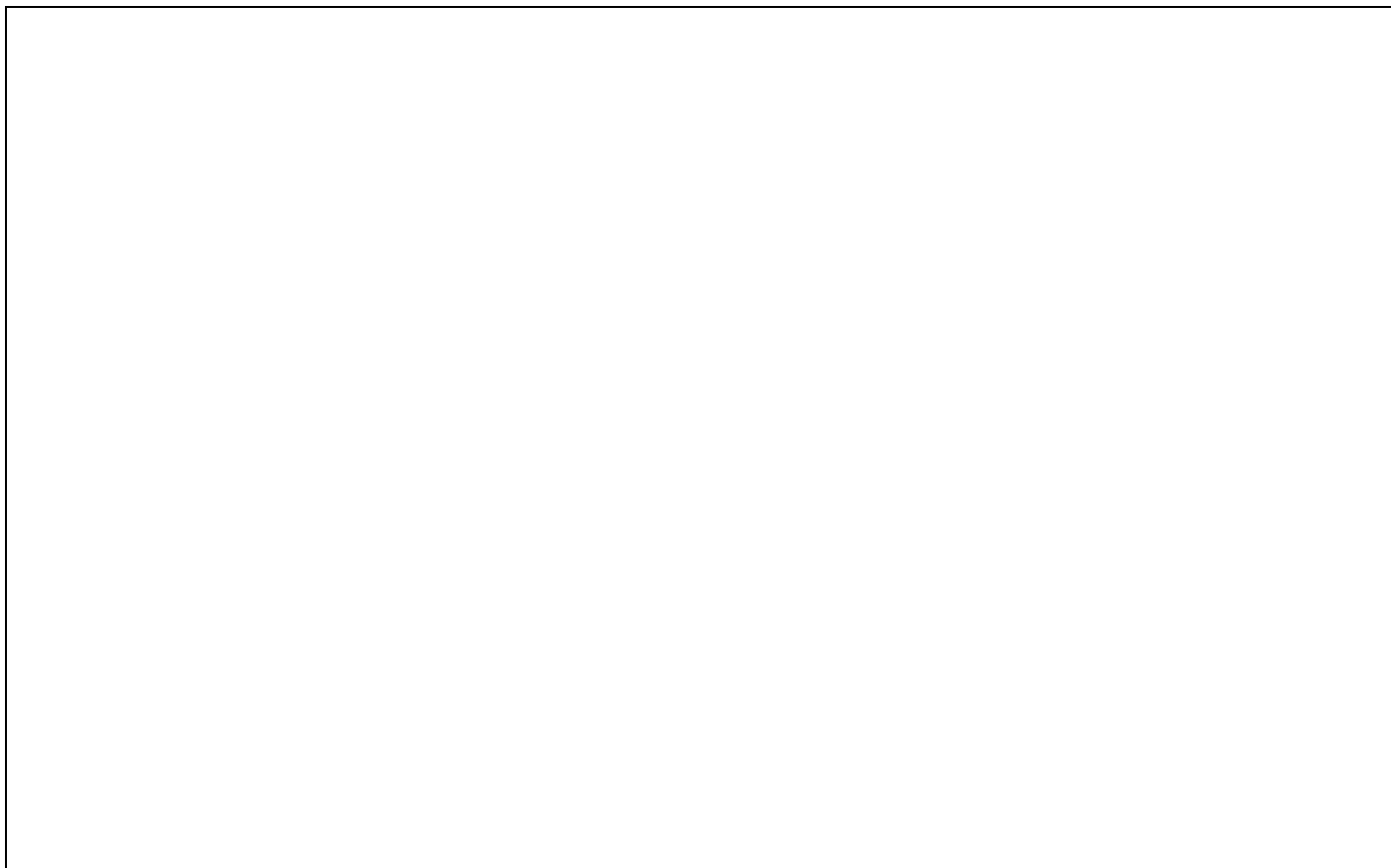

2- QUAL O NOME DA SUA RUA?



3- QUAL O NÚMERO DA SUA CASA?



4- QUAL O NOME DO BAIRRO QUE VOCÊ MORA?



ARTE

MASSINHA CASEIRA

VAMOS APRENDER A FAZER MASSINHA CASEIRA SUPER SIMPLES E COM UM CHEIRINHO AGRADÁVEL? PEÇA AJUDA A UM ADULTO, SIGA A RECEITA ABAIXO E MÃOS NA MASSA!



<https://www.soumae.org>

RECEITA:

1 XÍCARA DE FARINHA DE TRIGO

¼ XÍCARA DE SAL

¼ XÍCARA DE ÁGUA

1 PACOTE DE SUCO EM PÓ DA SUA PREFERÊNCIA

MODO DE FAZER:

MISTURE BEM TODOS OS INGREDIENTES POR APROXIMADAMENTE 4 MINUTOS. SE NECESSÁRIO, PODE ACRESCENTAR UM POUCO MAIS DE FARINHA, CASO FIQUE GRUDANDO NAS MÃOS E VAMOS À BRINCADEIRA!!!

TIRE UMA FOTO BEM BONITA DE VOCÊ BRINCANDO COM A MASSINHA E MANDE NO NOSSO GRUPO DO WATSAPP.

DIVIRTA-SE!!!

PROFª DIANA

MATEMÁTICA

1. CIRCULE E PINTE A **MAIOR** PILHA DE LIVROS.

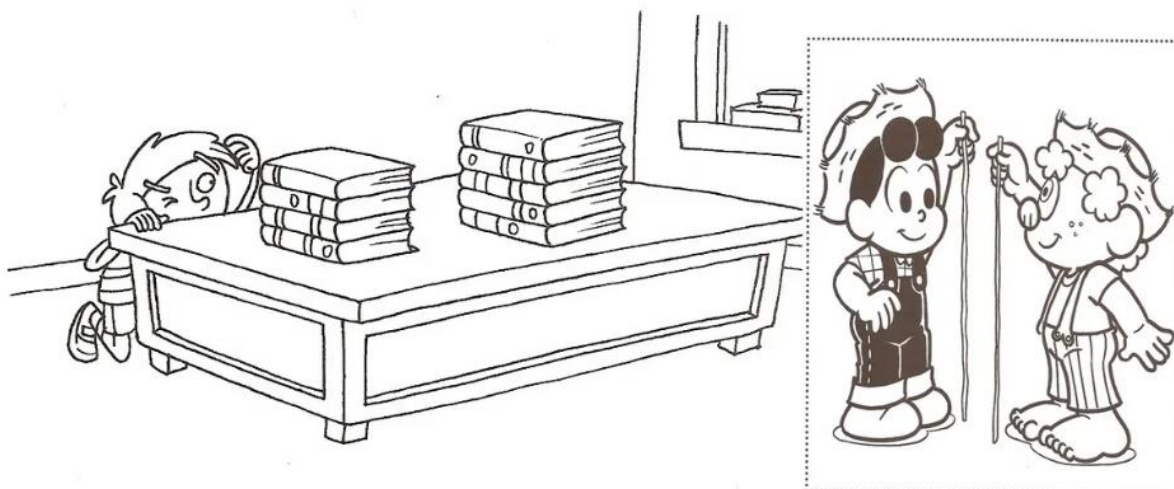

2. CIRCULE A FILA **MAIOR**, OU SEJA, A QUE CONTÉM MAIS CRIANÇAS.

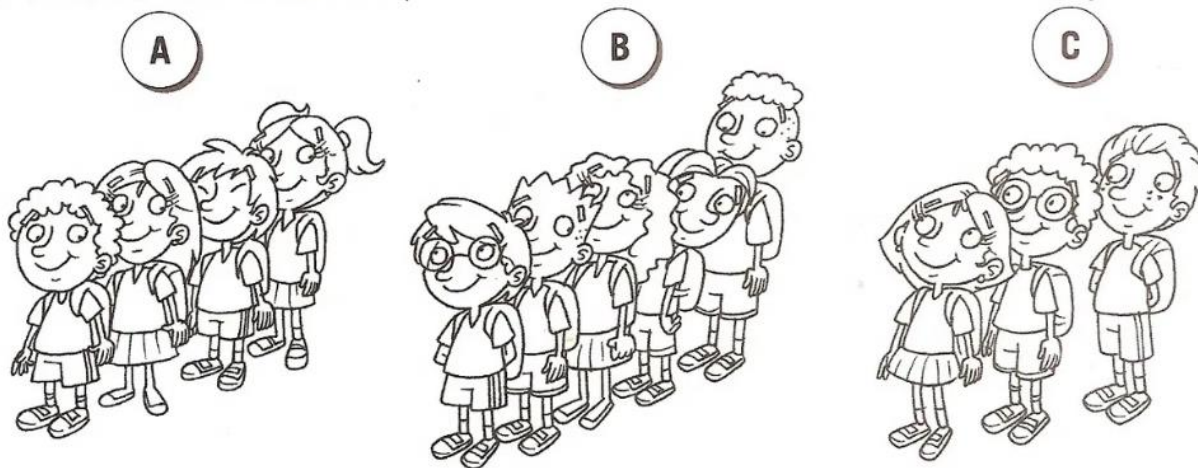

3. PINTE DE MARROM O ELEFANTE **MAIOR** E DE AMARELO O **MENOR**.

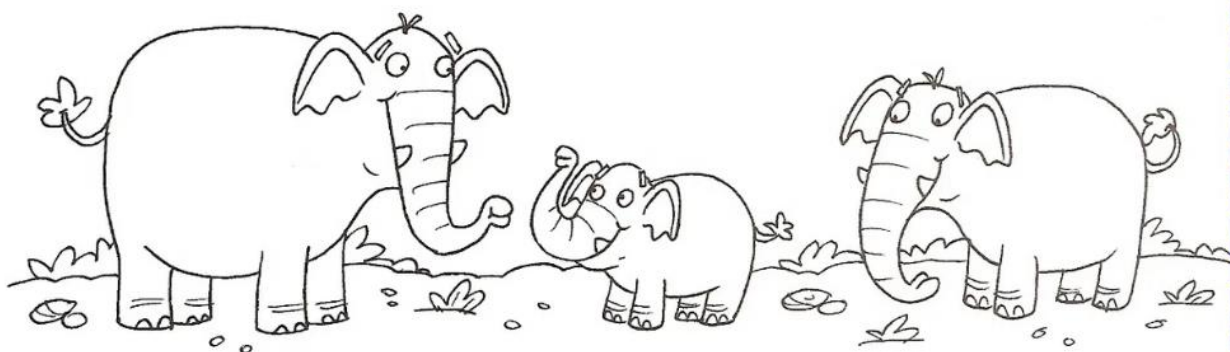

<https://onlinecursosgratuitos.com>

COMPRIDO OU CURTO

1. PINTE DE **LARANJA** A TOALHA MAIS **COMPRIDA** E DE **AZUL** A MAIS **CURTA**.

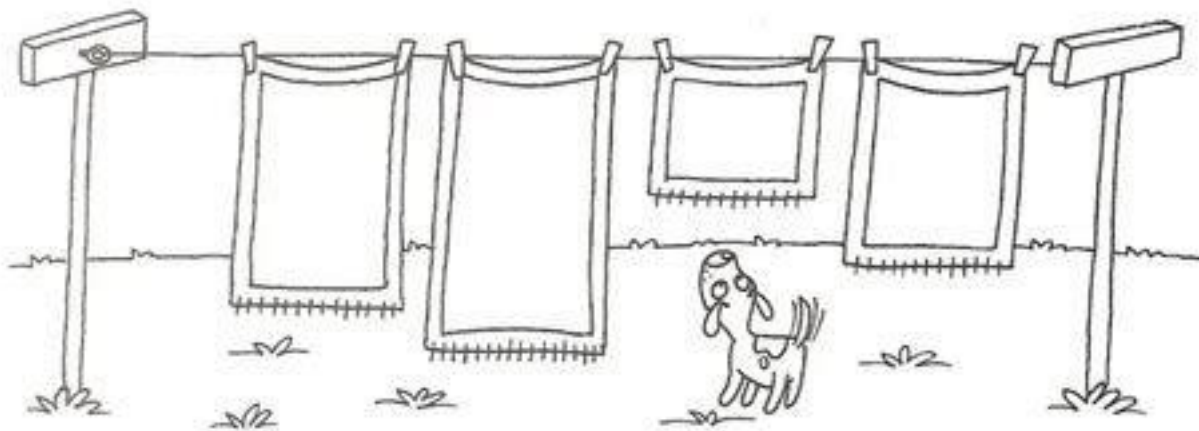

2. CIRCULE O LÁPIS MAIS **COMPRIDO** E MARQUE UM **X** AO LADO DO MAIS **CURTO**.

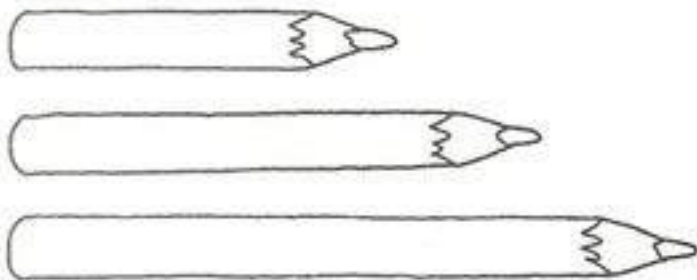

3. LIGUE O PÁSSARO À ESTACA MAIS **COMPRIDA** DA CERCA E A **BORBOLETA** À ESTACA MAIS **CURTA**.

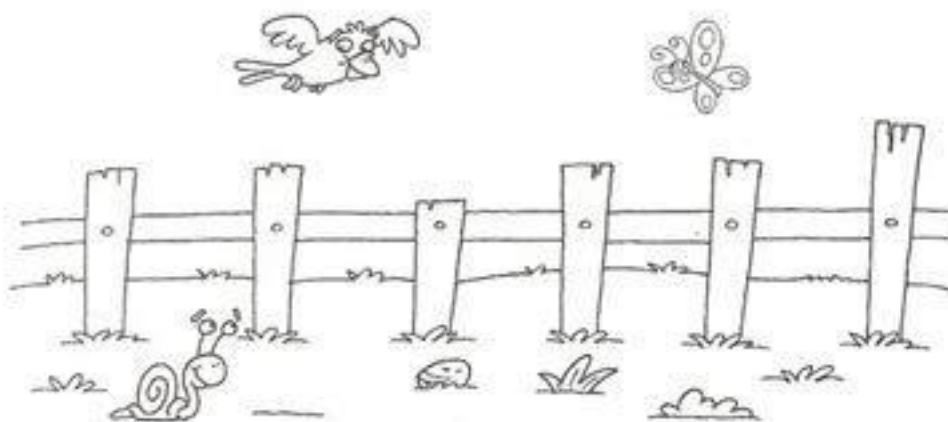

- PINTE O DESENHO ABAIXO, SEGUINDO AS ORIENTAÇÕES:

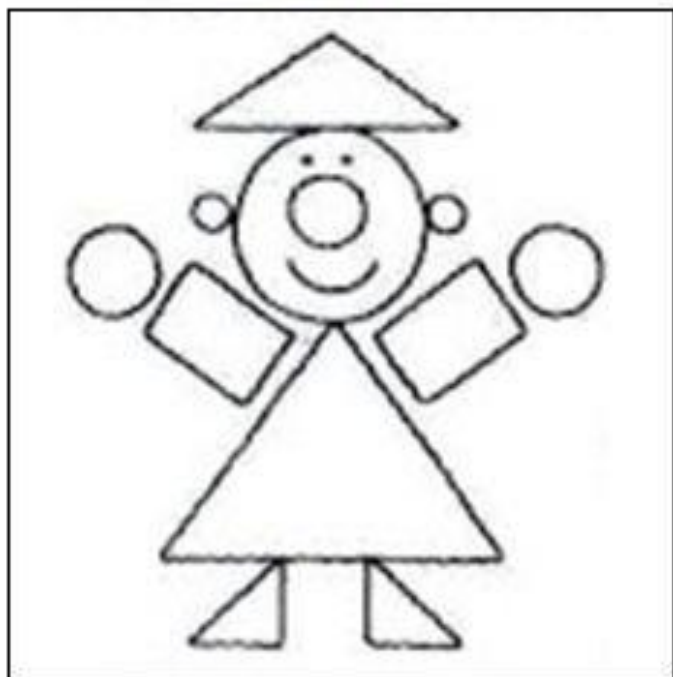

- PINTE A QUANTIDADE DE FORMAS GEOMÉTRICAS EXISTENTES NA IMAGEM ACIMA:

RETÂNGULO S

QUADRADOS

TRIÂNGULO

CÍRCULO

- CONTINUE A SEQUÊNCIA:



PORTUGUÊS

COM A AJUDA DE UM ADULTO, VAMOS LER O TEXTO ABAIXO E TREINAR O SOM DA LETRA C.

CORRE CUTIA

CORRE CUTIA
NA CASA DA TIA
CORRE CIPÓ
NA CASA DA VÓ
LENCINHO BRANCO
CAIU NO CHÃO
MOÇA BONITA
DO MEU CORAÇÃO



<https://israelakotona.blogspot.com/>

FAÇA UM X NO NOME DA FIGURA:



- CUTIA
- COTA
- CUECA



- CAMA
- CASACO
- CASA



- TEIA
- TICO
- TIA



- CINEMA
- CIPÓ
- CAFÉ



- AVÓ
- AVE
- ANEL

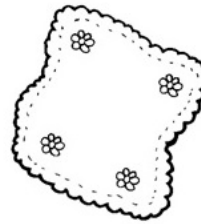

- LENCINHO
- LACINHO
- LANCHE

<https://israelakotona.blogspot.com/>

A LETRA DO DIA É ...

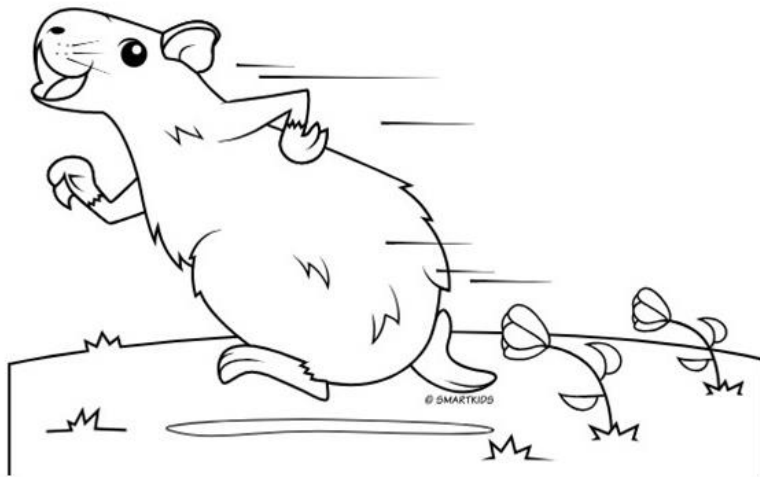

C

**ESCREVA NOS QUADROS A LETRA C .
ENCONTRE E PINTE AS FIGURAS INICIADAS PELA LETRA C .**

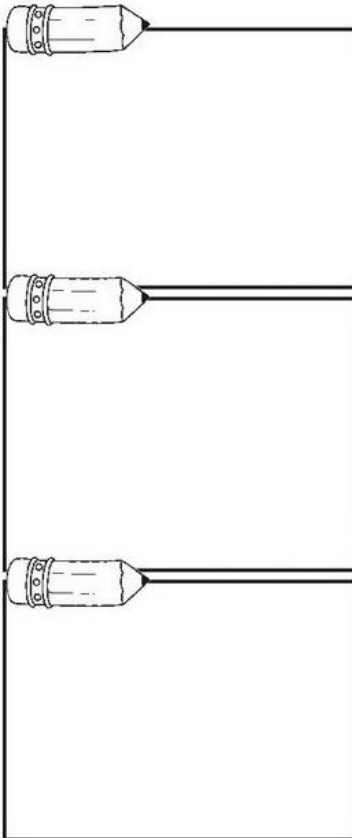

<https://israelakotona.blogspot.com/>

CORPO HUMANO

QUANTOS VOCÊ TEM?



CORPO

MATEMÁTICA

NOME: _____

- CONTE E DESCUBRA QUANTOS ANIMAIS HÁ EM CADA CONJUNTO:

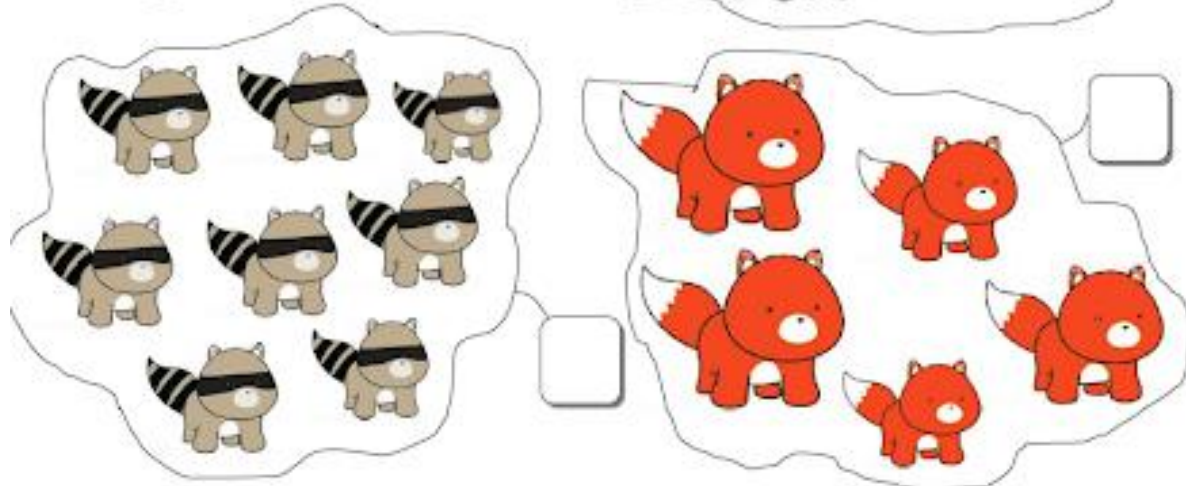
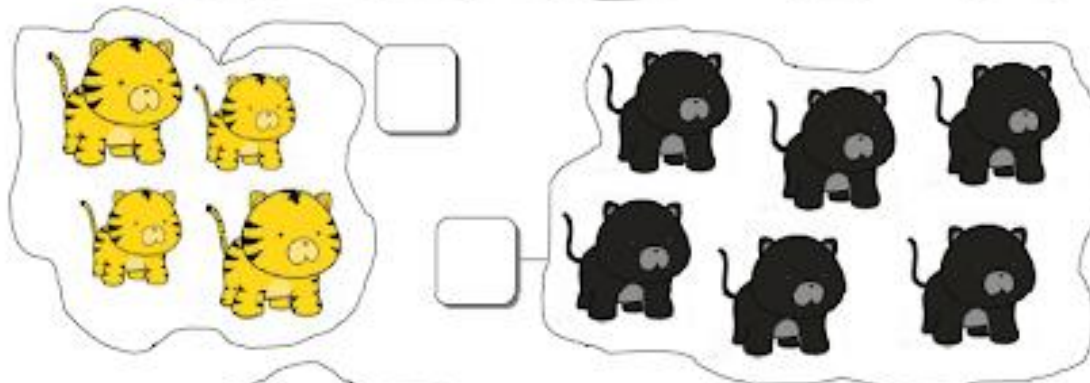
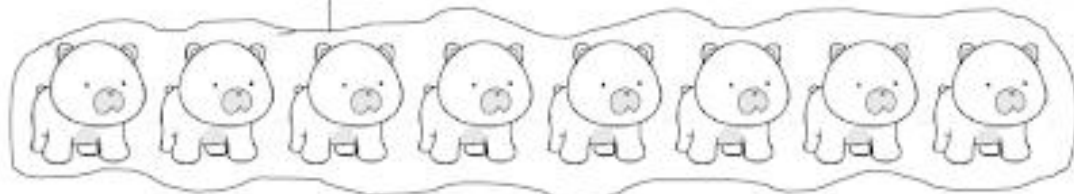
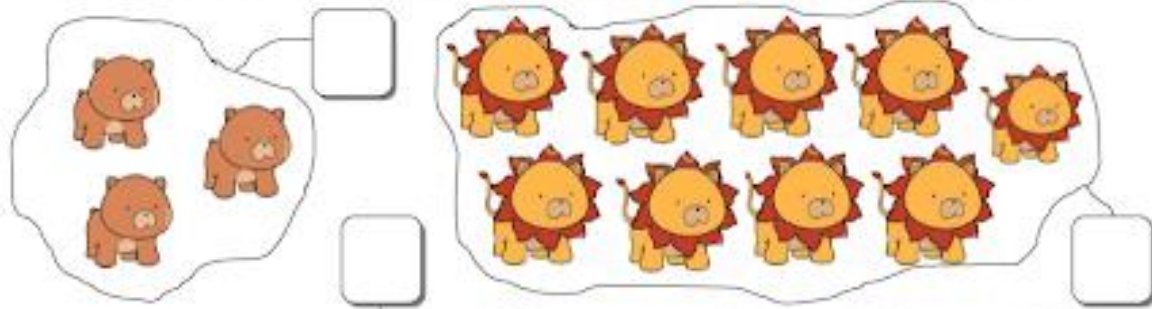

NOME:

DATA: / /

PROBLEMINHAS

NUMA FAZENDA HAVIA 8 VAQUINHAS E 3 BOIS. QUANTOS ANIMAIS A FAZENDA TINHA NO TOTAL?

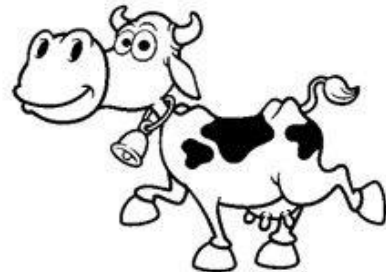

O AQUÁRIO DE ALICE POSSUI 5 PEIXINHOS DOURADOS E 4 PEIXES PALHAÇO. QUANTOS PEIXES NO TOTAL ALICE TEM?

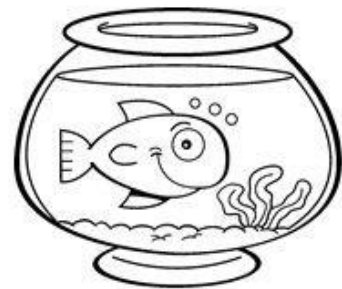

PEDRO TEM 7 CARRINHOS E FÁBIO TEM 6. JUNTOS ELES TEM QUANTOS CARRINHOS?

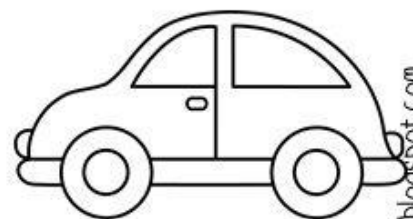

LARA COMPROU UMA BONECA DE 9 REAIS E UMA BOLA QUE CUSTOU 5 REAIS. QUANTO ELA GASTOU?



profrafaelak.blogspot.com

NOME _____

DATA ____/____/____



GRÁFICOS

OBSERVE O GRÁFICO DE UMA PESQUISA FEITA NA ESCOLA PARA SABER QUAL MEIO DE TRANSPORTE AS CRIANÇAS UTILIZAM PARA IR A ESCOLA E RESPONDA.

MEIOS DE TRANSPORTES

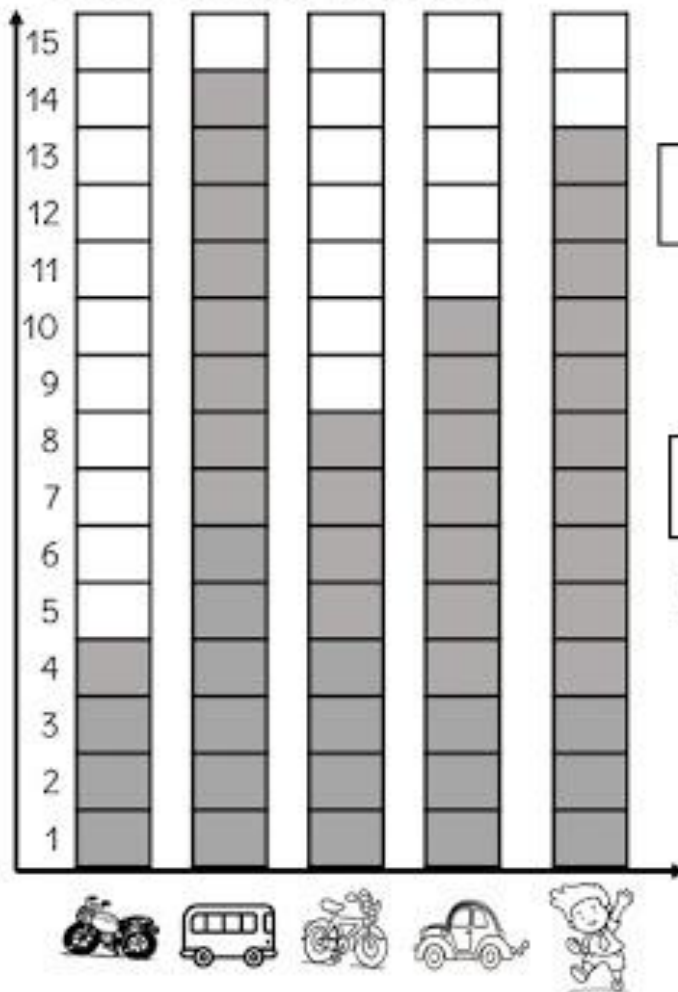

1- QUAL MEIO DE TRANSPORTE MAIS UTILIZADO?

2- QUAL MEIO DE TRANSPORTE MENOS UTILIZADO?

3- QUANTAS CRIANÇAS VEM A PÉ?

4- QUANTAS CRIANÇAS VEM DE CARRO E DE ÔNIBUS?

5- QUANTAS CRIANÇAS PARTICIPARAM DA PESQUISA?



I S R A E L A K O T O N A

ARTE

COMPLETE O DESENHO ABAIXO COM AS SUAS CARACTERÍSTICAS. NÃO SE ESQUEÇA DE DESENHAR A ROUPA QUE VOCÊ MAIS GOSTA.

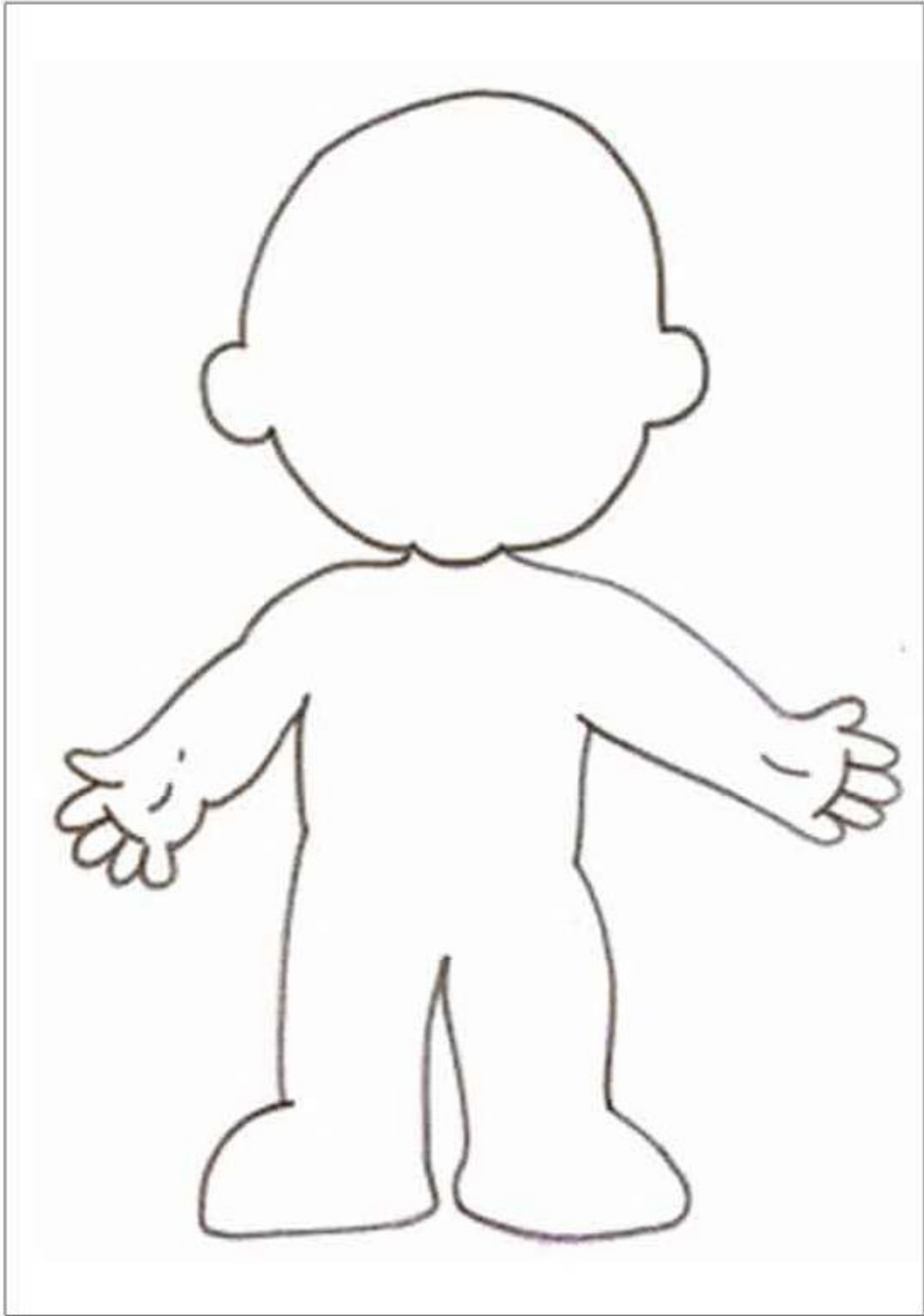

<https://www.mestredosaber.com.br/>

PORTUGUÊS

OBSERVE AS IMAGENS ABAIXO, NUMERE OS QUADRINHOS DE ACORDO COM A SEQUÊNCIA CORRETA E DESENHE UM FINAL PARA A HISTÓRIA.



<http://soranorma.blogspot.com/>

PORTUGUÊS

COM A AJUDA DE UM ADULTO, LEIA A PARLENDA ABAIXO:

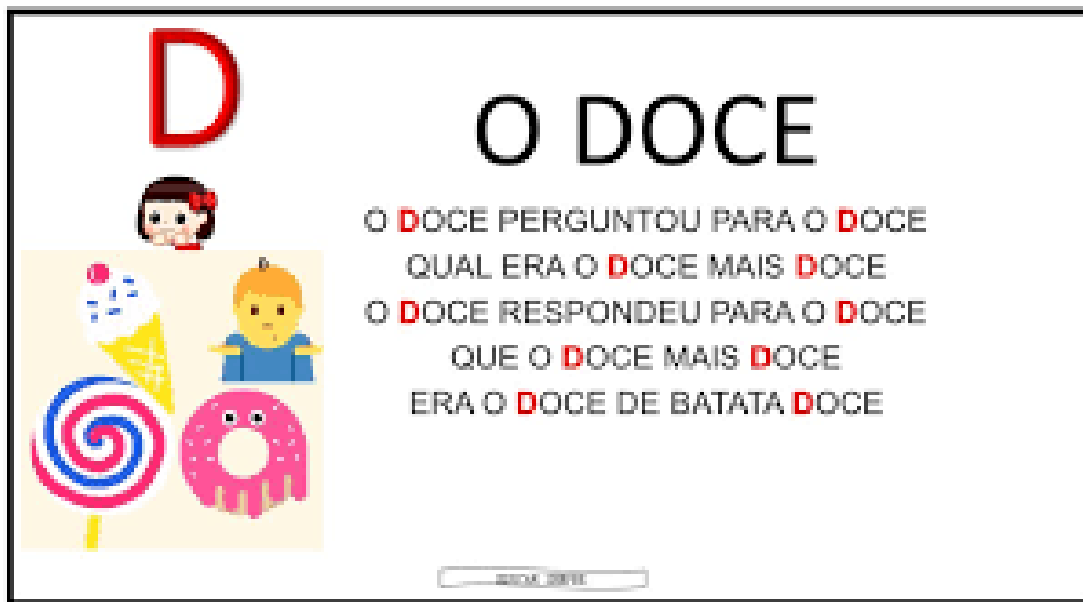

D

O DOCE

O **DOCE** PERGUNTOU PARA O **DOCE**
QUAL ERA O **DOCE** MAIS **DOCE**
O **DOCE** RESPONDEU PARA O **DOCE**
QUE O **DOCE** MAIS **DOCE**
ERA O **DOCE** DE BATATA **DOCE**

BRUNO ZETI

<https://educarsempre.com/>

1- QUAL É O DOCE MAIS DOCE, DE ACORDO COM O TEXTO?

RECORTE E COLE PAPEL COLORIDO NA LETRA D:

DA - DE - DI - DO - DU



DOCE

LEIA E COLE AS IMAGENS NO LUGAR INDICADO.



<https://educarsempre.com/>

MATEMÁTICA

1. Responda as questões:

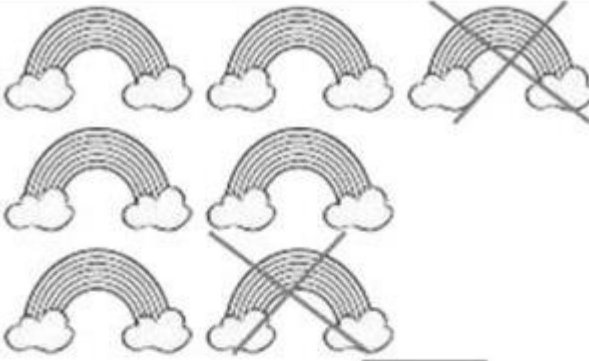
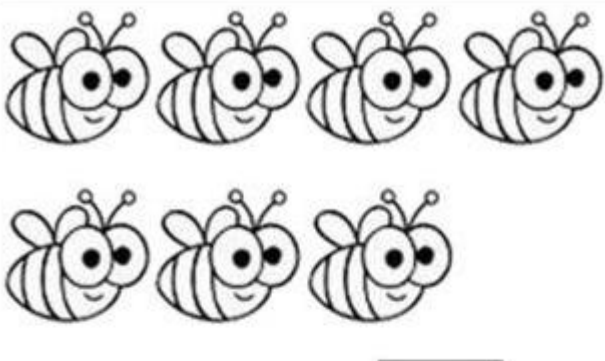
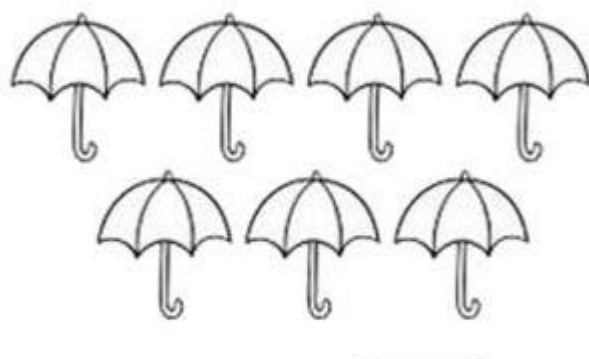
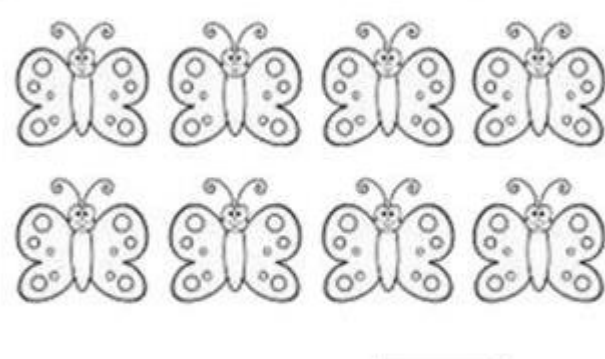
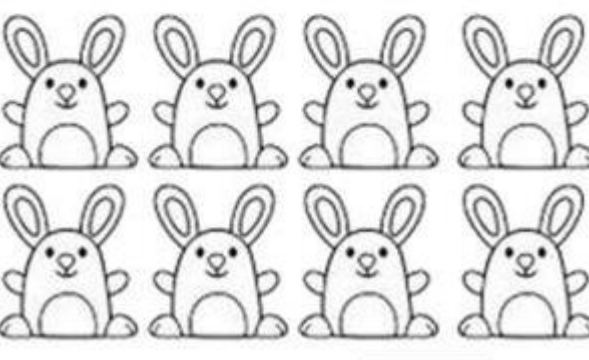
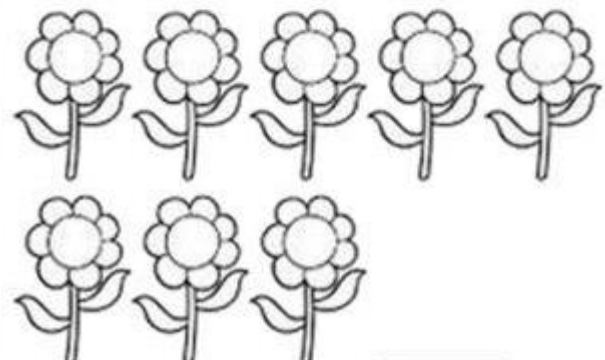
 <p>$7 - 2 = \boxed{5}$</p>	 <p>$7 - 3 = \square$</p>
 <p>$7 - 1 = \square$</p>	 <p>$8 - 6 = \square$</p>
 <p>$8 - 2 = \square$</p>	 <p>$8 - 4 = \square$</p>

SOME OS PONTOS DE CADA PEÇA DE DOMINÓ:

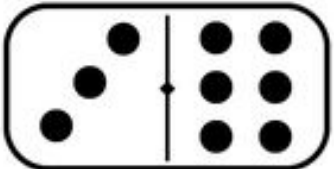
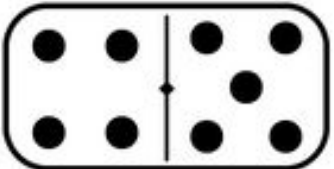
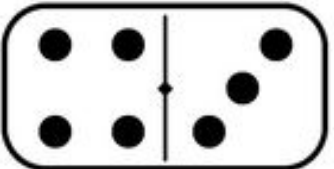
 $3 + 6 = 9$	 $+ \quad = \quad$	 $+ \quad = \quad$
--	--	--

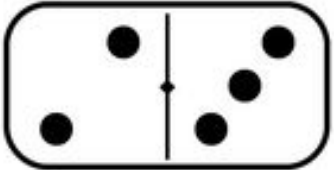
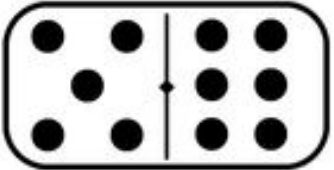
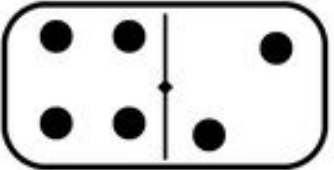
 $+ \quad = \quad$	 $+ \quad = \quad$	 $+ \quad = \quad$
--	--	--

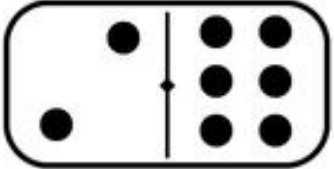
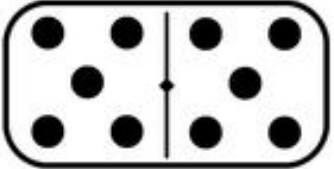
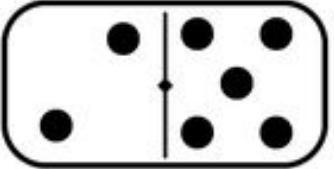
 $+ \quad = \quad$	 $+ \quad = \quad$	 $+ \quad = \quad$
---	---	---

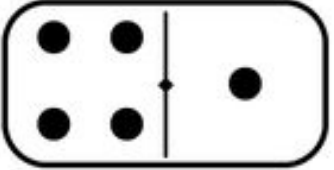
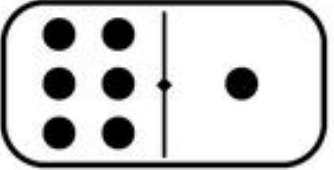

 $+ \quad = \quad$	 $+ \quad = \quad$
--	--

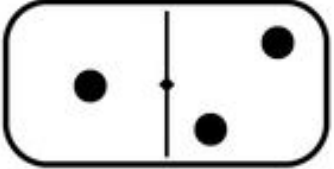
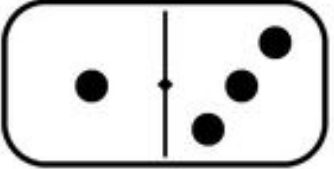
 $+ \quad = \quad$	 $+ \quad = \quad$
--	--

<https://br.pinterest.com/>

1- COMPLETE AS SEQUÊNCIAS NUMÉRICAS:

QUEM ESTÁ FALTANDO? 1 2 3 4 5 6 7 8 9 10

1		2		4		
2						
3...	6		8		10	

QUEM ESTÁ FALTANDO? 11 12 13 14 15 16 17 18 19 20

1	11		13		15	
2						
3...		17		19		

QUEM ESTÁ FALTANDO? 21 22 23 24 25 26 27 28 29 30

1	21		23			
2						
3...		27		29		

PORTUGUÊS

LEIA AS FRASES E MARQUE UM X NA FIGURA DE ACORDO COM A FRASE.

A COROA É DA RAINHA.



O GELO DERRETEU.



A JANELA ESTÁ ABERTA.



EU GOSTO DE JUJUBA.



FONTE: ISRAELA KOTONA

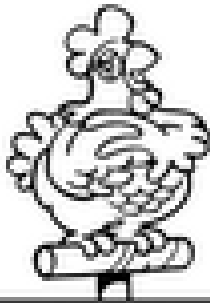

GALINHA

G



GATO

VAMOS COBRIR O PONTILHADO:

	G G G G G G G G
	G G G G G G G G

GA

GE

GI

GO

GU

1- COMPLETE AS PALAVRAS COM O SOM INICIAL:



TO



LO



RAFA



RILA



TO

G DE GENTE...

1- FAÇA O CONTORNO COM TINTA A DEDO, CUBRA COM GIZ COLORIDO E COPIE NO QUADRO.

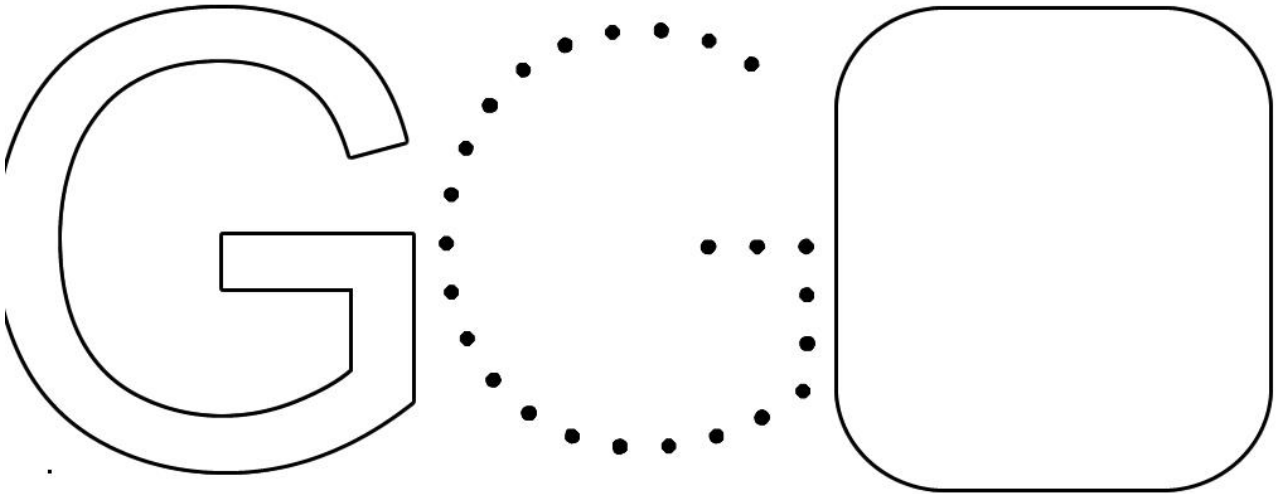

2- PINTE TODOS OS DESENHOS CUJO OS NOMES INICIAM COM A LETRA G



<http://www.aartedeensinareaprender.com>

UM GRANDE ABRAÇO!

PROF^a DIANA