

E.M. "RAIMUNDO VIEIRA BASTOS"

1º ANO A



https://image.freepik.com/vetores-gratis/criancas-brincam-de-casa-na-arvore_97632-662.jpg

6º REMESSA DE ATIVIDADES

ATIVIDADES DE 07/06 A 18/06/2021

PROFESSORA CAMILA MACHADO



Queridos alunos, pais e responsáveis:

Gostaria novamente de parabenizar a participação e o retorno das atividades por 90% da sala. Como já disse anteriormente, sei o quanto não é fácil dar conta das tarefas diárias mais as escolares de nossos filhos, mais infelizmente no momento, pensando na saúde e bem-estar de todos e para que os nossos filhos continuem se desenvolvendo no processo da aprendizagem, precisamos continuar com as atividades domiciliares.

Com fé, força e união vamos vencer essa batalha.

Para realização das atividades veja algumas orientações:



Realizar diariamente o cabeçalho “data”;



Respeite as datas das atividades, realizando diariamente e evitando assim o acúmulo;



Realize todas as atividades da apostila respeitando sempre a ordem das atividades, oportunizando o aluno de atingir os objetivos propostos;



Se houver dúvidas não hesite em chamar a professora que estará disponível para o esclarecimento das mesmas;



Procure entregar e retirar as apostilas sempre dentro do prazo;



Deixe que a criança realize suas atividades, de forma alguma faça por ela, precisamos deixar claro para os nossos filhos quais são suas funções e obrigações. Quando um adulto faz pela criança se perde autoridade e principalmente o aprendizado, na qual a atividade não terá objetivo nenhum a não ser de cumprir protocolos.



Lembre-se que nesse momento a avaliação se faz exclusivamente pelas atividades realizadas nas apostilas, livros didáticos e por meio de registros, de fotos ou vídeos. Não deixe de enviar esses registros pelo menos duas vezes na semana, para que a professora possa avaliar o desenvolvimento dessas atividades pelos alunos.



A devolução dessa apostila que estão recebendo no dia de hoje (08/06), será 22/06 (Terça-feira).

Att. Professora Camila Machado

ATIVIDADES REFERENTE AO DIA 07/06/21

DATA: _____

NOME: _____

CIÊNCIAS

5 DE JUNHO DIA DO MEIO AMBIENTE



O AMBIENTE

ISABEL CRISTINA SILVEIRA SOARES

VAMOS LOGO CRIANÇADA
O NOSSO MUNDO DEFENDER
ENSINAR QUE O AMBIENTE
SOMOS NÓS, EU E VOCÊ!

CADA UM É RESPONSÁVEL
PELA VIDA E O BEM VIVER
O AMBIENTE, A SEMENTE
OS ANIMAIS, EU E VOCÊ!

VAMOS CANTAR NO RITMO DE CIRANDA, CIRANDINHA.

- CIRCULE NO TEXTO TODAS AS PALAVRAS COM A LETRA M. DEPOIS ESCREVA ABAIXO:

_____	_____
_____	_____
_____	_____
_____	_____

MATEMÁTICA

VAMOS COLORIR DE ACORDO COM A LEGENDA:



- | | | |
|--------------|-------------|-----------|
| 1 = VERDE | 2 = MARROM | 3 = CREME |
| 4 = AZUL | 5 = AMARELO | 6 = ROSA |
| 7 = VERMELHO | 8 = LARANJA | |

https://1.bp.blogspot.com/-7fmiuN0k4vs/YKxTc_rLw5I/AAAAAAAAAko4/L-

[TaTVISvzEZI8WB0UDM_9fpe3GHf4NwCLcBGAsYHQ/s1040/101075917_141436554172532_7378573524685815808_n.jpg](https://1.bp.blogspot.com/-7fmiuN0k4vs/YKxTc_rLw5I/AAAAAAAAAko4/L-TaTVISvzEZI8WB0UDM_9fpe3GHf4NwCLcBGAsYHQ/s1040/101075917_141436554172532_7378573524685815808_n.jpg)

ATIVIDADES REFERENTE AO DIA 08/06/21

DATA: _____

NOME: _____

LÍNGUA PORTUGUESA



1. ENCONTRE AS PALAVRAS QUE ESTÃO NO NOSSO CAÇA – PALAVRAS.

O E R T T E C O N O M I Z A R A H C
O H F T C A E N E W T F S S N O I E
G O O A Á G U A F N O A E I N A M D
T N T E M H N T T T Ú A M I P P O R
N T U L E A H U E D O A W O L L N F
H T R O T S E R E C I C L A R F A I
L I U A T T O E L S S U N U T S R T
C O G K E F D Z U D I T E Y E R G N
N T O I B N I A N Ç A S D E T N S L
P O O O E F D A ã S A E E A B L O N
O V O H I N L O E T O S L L M N I F
F A D P Y E E A T P O E E L D I I T

**ANIMAIS – ECONOMIZAR – HIGIENE – NATUREZA –
PLANTAS – POLUIÇÃO – RECICLAR – SAÚDE - ÁGUA**

CIÊNCIAS

FAÇA A ILUSTRAÇÃO ABAIXO DE ATITUDES QUE DEIXAM NOSSO PLANETE FELIZ OU TRISTE:



ATIVIDADES REFERENTE AO DIA 09/06/21

DATA: _____

NOME: _____

ARTES



OBSERVE O MODELO COMO BASE.

PINTE O DESENHO DO PLANETA, FAÇA O DESENHO DE SEUAS MÃOS NA PÁGINA A SEGUIR, PINTE, RECORTE E MONTE NA PÁGINA INDICADA.

NÃO DEIXE DE ACOMPANHAR A ORIENTAÇÃO NO GRUPO DA ESCOLA.



<https://i.pinimg.com/564x/aa/d0/98/aad0980207727808b021aee5aff105b6.jpg>



DESENHE SUAS MÃOS AQUI:

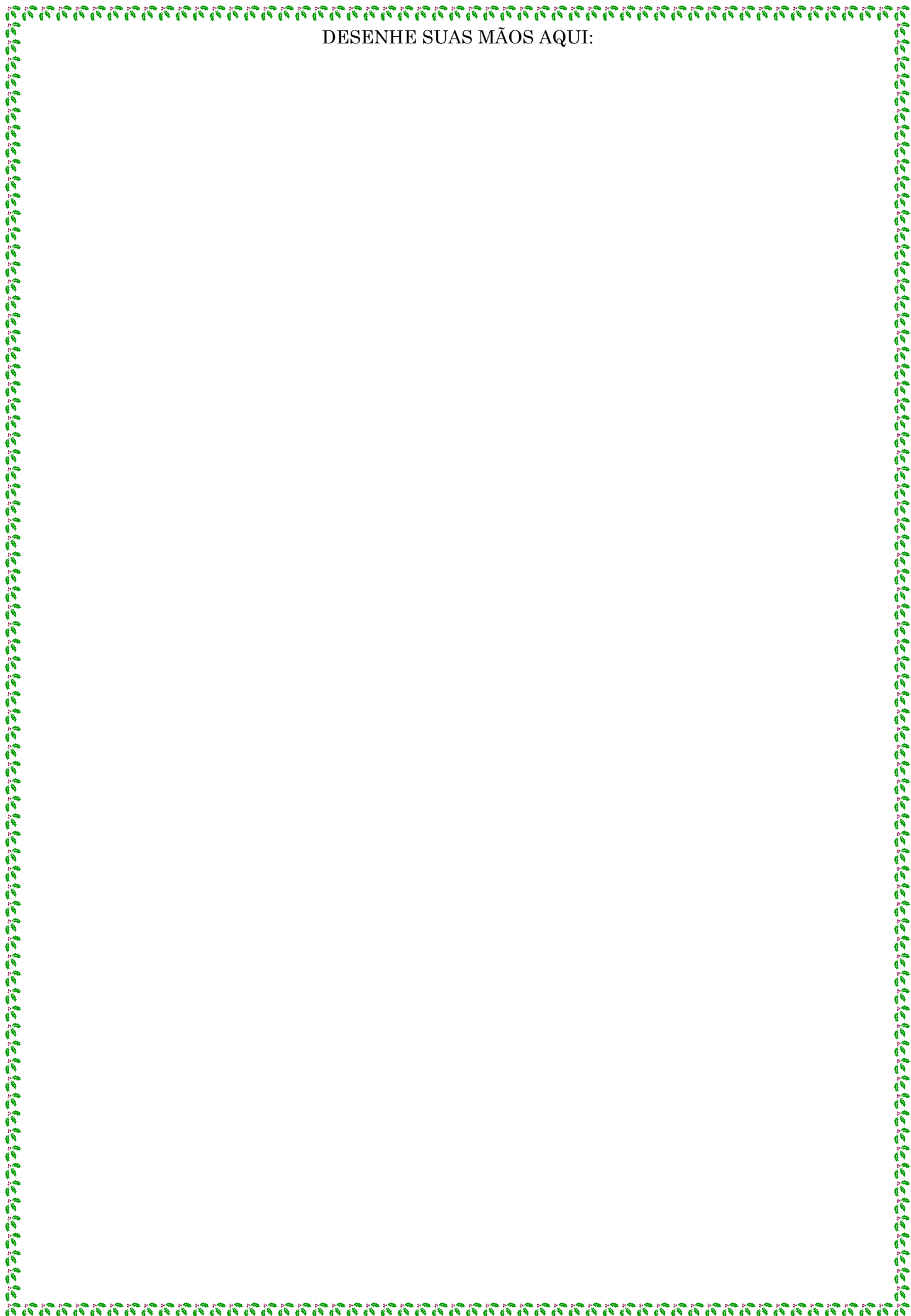

MONTE AQUI SEU DESENHO:

ATIVIDADES REFERENTE AO DIA 10/06/21

DATA: _____

NOME: _____

LÍNGUA PORTUGUESA

A LETRINHA QUE IREMOS ESTUDAR NOS PRÓXIMOS DIA É A LETRA 

TENTE IMITAR O MA DE MACACO PARA
REPRODUZIR O SOM DESSA LETRA:

M



VAMOS LER A PARLENDA:

O MACACO FOI À FEIRA

O MACACO FOI À FEIRA,
NÃO SABIA O QUE COMPRAR.
COMPROU UMA CADEIRA,
PRA COMADRE SE SENTAR.
A COMADRE SE SENTOU.
A CADEIRA ESCORREGOU.
COITADA DA COMADRE,
FOI PARAR NO CORREDOR.





FALANDO SOBRE O TEXTO:

1- QUEM FOI À FEIRA?

- MALUCO
- MACACO
- MARRECO



2- O QUE O MACACO COMPROU?

- CAVEIRA
- COLEIRA
- CADEIRA

3 - PARA QUEM ERA A CADEIRA?

- COMADRE
- COMPADRE
- COMIDA



4 - O QUE ACONTECEU COM A CADEIRA QUANDO A COMADRE SE SENTOU?

- ESPIRROU
- ESBORRACHOU
- ESCORREGOU



MATEMÁTICA

O MACACO FOI À FEIRA COMPROU ALGUMAS CADEIRAS...

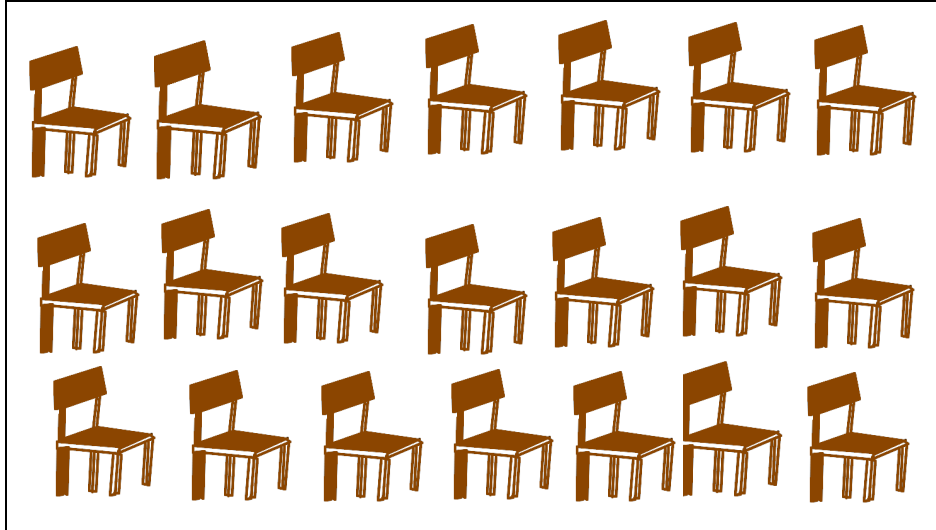

QUANTAS CADEIRAS O MACACO COMPROU?

RESOLVA AS OPERAÇÕES:

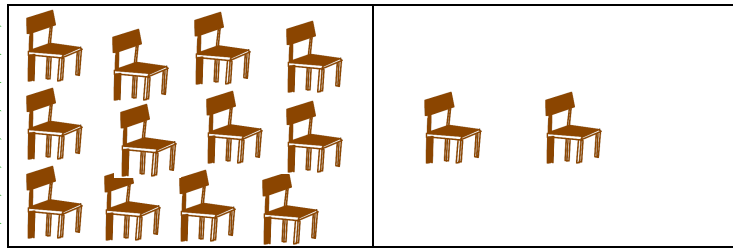

_____ + _____ = _____

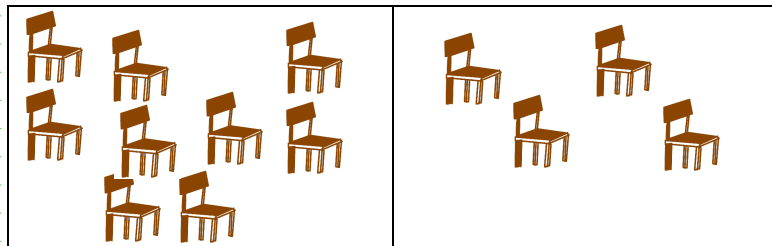

_____ + _____ = _____

ATIVIDADES REFERENTE AO DIA 11/06/21

DATA: _____

NOME: _____

LÍNGUA PORTUGUESA

RECORTE E COLE AS IMAGENS NO QUADRO QUE REPRESENTA SEU NOME:

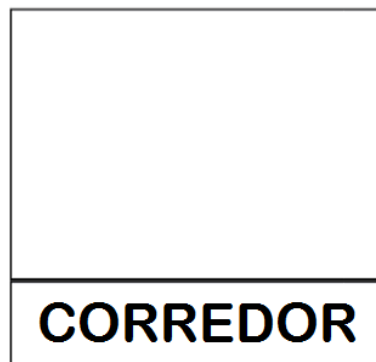
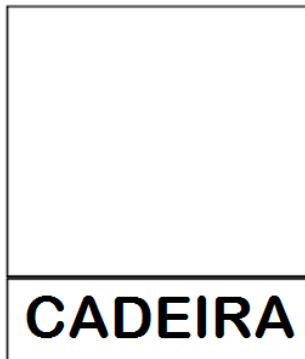
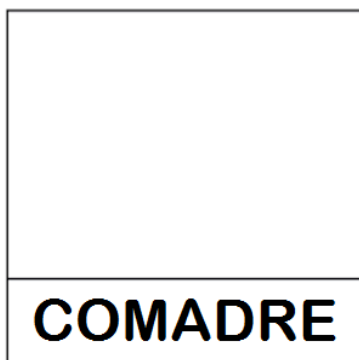
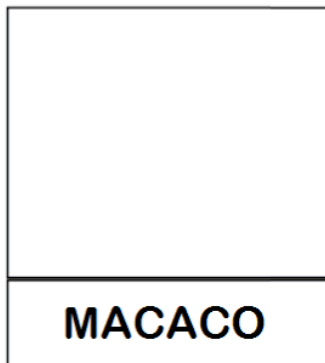

MATEMÁTICA

CALENDÁRIO

COMPLETE O CALENDÁRIO:



JUNHO DE 2021

Dom	Seg	Ter	Quar	Qui	Sex	Sab

ATIVIDADES REFERENTE AO DIA 14/06/21

DATA: _____

NOME: _____

LÍNGUA PORTUGUESA

PINTE O PEDACINHO DA PALAVRA COM O SOM DA LETRA:

M



○ ○ ○

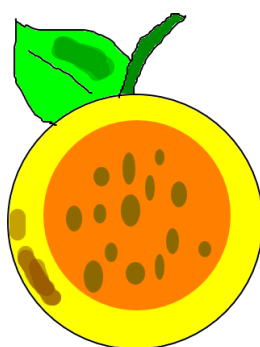

○ ○ ○ ○



○ ○ ○

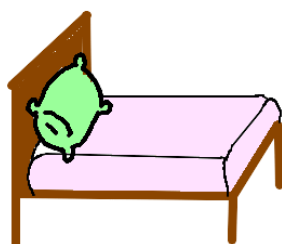

○ ○

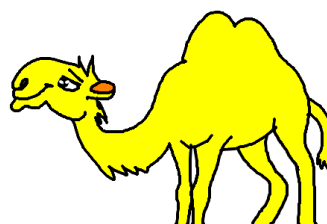

○ ○ ○



○ ○ ○











MATEMÁTICA



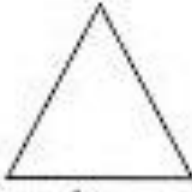

FIGURAS GEOMÉTRICAS

PINTE AS FORMAS QUE SÃO SEMELHANTES A PRIMEIRA DE CADA QUADRO:

 QUADRADO			
---	---	--	---

 CÍRCULO			
---	--	--	--

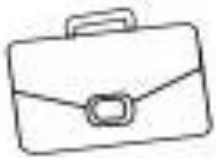
 TRIÂNGULO			
--	---	--	---

 RETÂNGULO			
--	---	--	---

ATIVIDADES REFERENTE AO DIA 15/06/21

DATA: _____

NOME: _____

LÍNGUA PORTUGUESA



COMPLETE A PARLENDAS COM AS PALAVRAS QUE FALTAM.

O _____ FOI À _____,

NÃO SABIA O QUE COMPRAR.

COMPROU UMA _____,

PRA _____ SE SENTAR.

A _____ SE SENTOU.

A _____ ESCORREGOU.

COITADA DA _____

FOI PARAR NO CORREDOR.



MACACO



FEIRA



CADEIRA



COMADRE



MATEMÁTICA

HOJE FOI O DIA DO MACACO IR A FEIRA FAZER UMA COMPRA DE FRUTAS. OBSERVE O GRÁFICA E RESPONDA AS QUESTÕES:

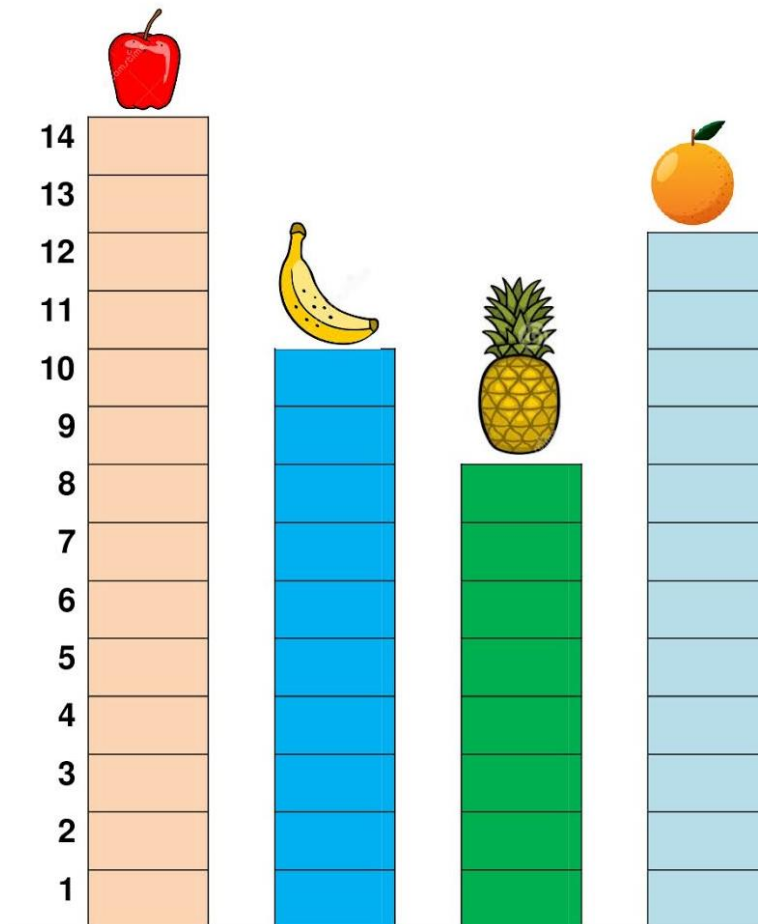

[https://1.bp.blogspot.com/-](https://1.bp.blogspot.com/-ahm08CSbOXw/X2qPMnXKa1I/AAAAAAAAAcI/EOZ8oCPEKOUOFUAPxugpj2ibShT5Ku6MQCLcBGAsYHQ/s2048/grafico-sequencias.jpg)

[ahm08CSbOXw/X2qPMnXKa1I/AAAAAAAAAcI/EOZ8oCPEKOUOFUAPxugpj2ibShT5Ku6MQCLcBGAsYHQ/s2048/grafico-sequencias.jpg](https://1.bp.blogspot.com/-ahm08CSbOXw/X2qPMnXKa1I/AAAAAAAAAcI/EOZ8oCPEKOUOFUAPxugpj2ibShT5Ku6MQCLcBGAsYHQ/s2048/grafico-sequencias.jpg)

RESPONDA DE ACORDO COM AS INFORMAÇÕES DO GRÁFICO:

1- QUAL FRUTA O MACACO COMPROU EM MAIOR QUANTIDADE?

2- QUAL FRUTA ELE COMPROU EM MENOR QUANTIDADE?

3- QUANTAS LARANJAS ELE COMPROU?

4- QUAL DESSAS FRUTAS ELE COMPROU DEZ UNIDADES?

ATIVIDADES REFERENTE AO DIA 16/06/21

DATA: _____

NOME: _____

LÍNGUA PORTUGUESA

ATIVIDADES COM SÍLABAS E PALAVRAS LETRA M:



NÃO DEIXE DE ACOMPANHAR AS ORIENTAÇÕES NO GRUPO DA ESCOLA.



[Empty box]				
↓ ↓ ↓ ↓ ↓				
A	E	I	O	U
↓ ↓ ↓ ↓ ↓				
[Empty box]	[Empty box]	[Empty box]	[Empty box]	[Empty box]
↓ ↓ ↓ ↓ ↓				
[Empty box]	[Empty box]	[Empty box]	[Empty box]	[Empty box]
↓ ↓ ↓ ↓ ↓				
[Empty box]	[Empty box]	[Empty box]	[Empty box]	[Empty box]

RECORTE E REALIZE A ATIVIDADE DAS LETRAS E SÍLABAS:



M

MA

ME

MI

MO

MU

MALA

MESA

MICO

MOTO

MURO



MICO

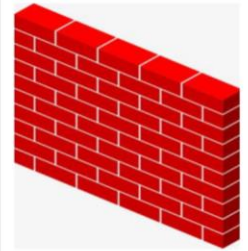

<https://atividadesparaprofessores.com.br/wp-content/uploads/Atividades-com-s%C3%ADlabas-e-palavras-12-1920x1358.jpg>

MATEMÁTICA

VAMOS AJUDAR O MACACO A RESOLVER AS SITUAÇÕES PROBLEMA:



NUMA FAZENDA HAVIA 8 VAQUINHAS E 3 BOIS. QUANTOS ANIMAIS A FAZENDA TINHA NO TOTAL?

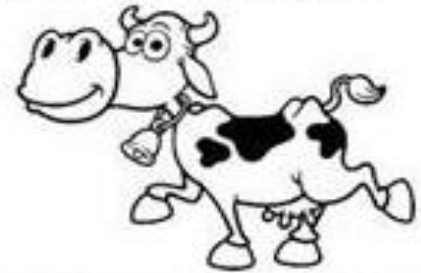

O AQUÁRIO DE ALICE POSSUI 5 PEIXINHOS DOURADOS E 4 PEIXES PALHAÇO. QUANTOS PEIXES NO TOTAL ALICE TEM?

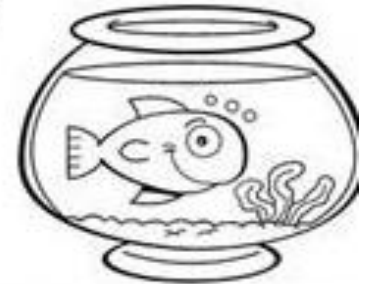

PEDRO TEM 7 CARRINHOS E FÁBIO TEM 6. JUNTOS ELES TEM QUANTOS CARRINHOS?

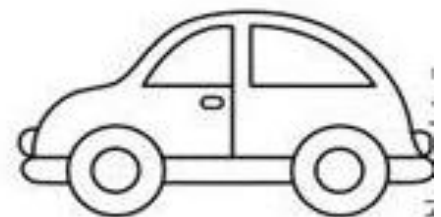

LARA COMPROU UMA BONECA DE 9 REAIS E UMA BOLA QUE CUSTOU 5 REAIS. QUANTO ELA GASTOU?



ATIVIDADES REFERENTE AO DIA 17/06/21

DATA: _____

NOME: _____

LÍNGUA PORTUGUESA





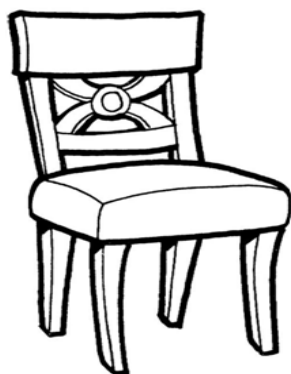





































ESCREVA DO SEU JEITINHO:



MATEMÁTICA

DESCUBRA OS NÚMEROS QUE ESTÃO NO LUGAR DOS SÍMBOLOS.

1	2	3		5			8		
11			14		16	17		19	20
21		23		25	26		28		30
31	32		34	35		37		39	40
41	42	43			46			49	50

	<input type="text"/>		<input type="text"/>		<input type="text"/>		<input type="text"/>
	<input type="text"/>		<input type="text"/>		<input type="text"/>		<input type="text"/>
	<input type="text"/>		<input type="text"/>		<input type="text"/>		<input type="text"/>
	<input type="text"/>		<input type="text"/>		<input type="text"/>		<input type="text"/>
	<input type="text"/>		<input type="text"/>		<input type="text"/>		<input type="text"/>

ATIVIDADES REFERENTE AO DIA 18/06/21

DATA: _____

NOME: _____

ARTES

ATIVIDADE DE RECORTE E COLAGEM



PINTE, RECORTE E MONTE:



MONTE AQUI SEU MACACO