



PREFEITURA DA ESTÂNCIA TURÍSTICA DE  
**IBIÚNA**  
Por uma Ibiúna próspera. Investindo no presente, gerando o futuro.  
**SECRETARIA DE EDUCAÇÃO**



Rua Raimundo Santiago, nº 27 - Centro  
Telefone: (15) 3248-1292/e-mail: apoiopedagogicosmeibiuna@hotmail.com

# OLIMPIÁDAS COM A TURMA DA MÔNICA

[www.materiaispdg.com.br](http://www.materiaispdg.com.br)



MARILIO

## **Cronograma**

**5/07** PINTAR A CAPA E HISTÓRIA DA OLIMPÍADA

**06/07** JOGO DO 7 ERROS / TREINANDO A-D

**19/07** QUAL É A PALAVRA CERTA/ TREINANDO E-H

**20/07** CAÇA PALAVRA / TREONANDO I-L

**21/07** CONTAR AS BOLAS / TREINANDO M- P

**22/07** PINTAR O CAMINHO / TREINANDO Q-T

**23/07** HANDBOL / TREINANDO U-Z

**26/07** BOXE / ENCONTRE OS NÚMEROS

**27/07** CANOAGEM/ PINTE O SORVETE

**28/07** FUTEBOL / DESENHE O SAPINHO REPRESENTANDO SUA IDADE

**29/07** TRIATLO/ GRAVAR SUA BRINCADEIRA PREFERIDA

**30/07** CICLISMO/ LEITURA DEPOIS DESENHAR NO CADERNO DE DESENHO A HISTÓRIA

**02 /08** COMPLETE A SEQUÊNCIA/ FAZER UM BOLO DE IMAGINAÇÃO, NESSE MOMENTO VAMOS CAPRICHAR NO BOLO DE BARRO ou AREIA, ENFEITAR COM FLORZINHA

**03/08** JOGO DA MEMÓRIA ( RECORTAR) / JOGAR FUTEBOL NO QUINTAL DA CASA

**04/08** AS CORES DA MEDALHAS/ PINTAR A BANDEIRA

**05/08** TÊNIS/ CRIAR UM BONECO DE BEXIGA E FARINHA

**06/08** DESENHAR SEU ESPORTE FAVORITO NO CADERNO DE DESENHO/ APROVEITAR PARA COLOCAR EM DIA AS ATIVIDADES NÃO REALIZADA

**= 17 dias.**

## JOGOS OLÍMPICOS

A QUATRO ANOS, ATLETAS DE CENTENAS DE PAÍSES SE REÚNEM NUM PAÍS SEDE PARA DISPUTAREM UM CONJUNTO DE MODALIDADES ESPORTIVAS. A PRÓPRIA BANDEIRA OLÍMPICA REPRESENTA ESSA UNIÃO DE POVOS E RAÇAS, POIS É FORMADA POR CINCO ANÉIS ENTRELAÇADOS, REPRESENTANDO OS CINCO CONTINENTES E SUAS CORES. A PAZ, A AMIZADE E O BOM RELACIONAMENTO ENTRE OS POVOS SÃO OS PRINCÍPIOS DOS JOGOS OLÍMPICOS.

### ORIGEM DOS JOGOS OLÍMPICOS

FORAM OS GREGOS QUE CRIARAM OS JOGOS OLÍMPICOS. POR VOLTA DE 2500 A.C. OS GREGOS JÁ FAZIAM HOMENAGENS AOS DEUSES, PRINCIPALMENTE ZEUS, COM REALIZAÇÃO DE COMPETIÇÕES. PORÉM, FOI SOMENTE EM 776 A.C QUE OCORRERAM PELA PRIMEIRA VEZ OS JOGOS OLÍMPICOS, DE FORMA ORGANIZADA E COM PARTICIPAÇÃO DE ATLETAS DE VÁRIAS CIDADES-ESTADO.

### JOGOS OLÍMPICOS DE TÓQUIO

A EDIÇÃO DE 2020 FOI ADIADA PARA O ANO DE 2021, POR CONTA DA PANDEMIA DE CORONAVÍRUS. OS JOGOS ACONTECERÃO EM TÓQUIO, NO JAPÃO, DE 23 DE JULHO À 08 DE AGOSTO.

MIRAITOWA É A MASCOTE OFICIAL DOS JOGOS OLÍMPICOS DE TÓQUIO E SOMEITY É A MASCOTE OFICIAL DOS JOGOS PARALÍMPICOS.



MIRAITOWA



SOMEITY

# VOLEI DE PRAIA

"IR BUSCAR UMA BOLA LONGE, SEM DEIXÁ-LA CAIR."

VAMOS DESCOBRIR AS 7 DIFERENÇAS!!

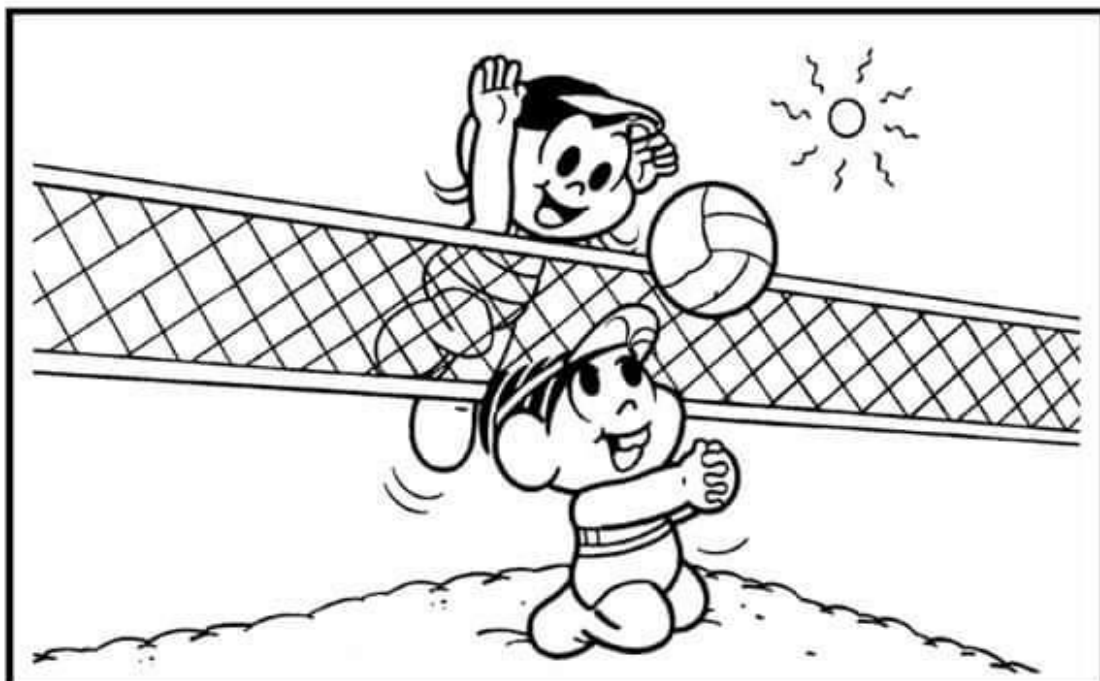
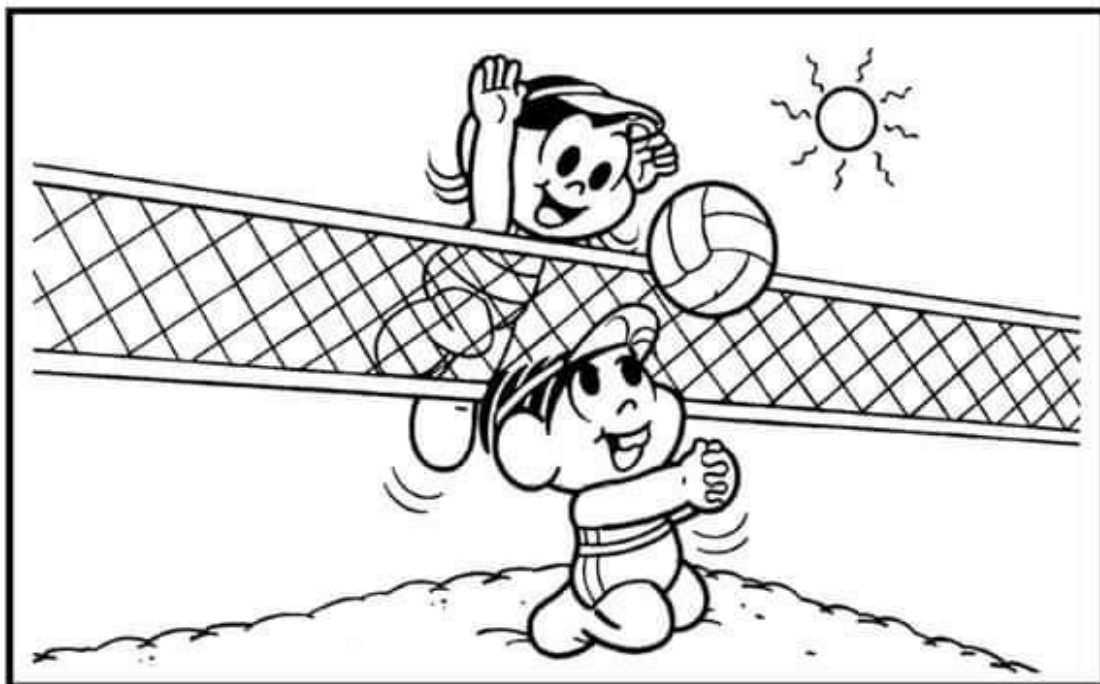



*Mistura de Alegria*

# ATIVIDADE LEGAL

A

B

CIRCULE A PALAVRAS DE ACORDO COM O NOME DE CADA FIGURA:



PAPÉIS  
PASTÉIS  
ANÉIS



ARMÁRIO  
ARCO  
ARGOLA



ARTE  
ARCO  
ARGOLA



BINGO  
BICICLETA  
BISTECA



ALVO  
ALMA  
ALTO



BOLA  
BOTA  
BOCA



PALITO  
APITO  
BONITO



BRAVO  
BRASA  
BRASIL

# BADMINTON

"MOVIMENTAR-SE RÁPIDO E REBATER A PETECA."



VAMOS PROCURAR E PINTAR A  
PALAVRA PETECA NO QUADRO ABAIXO!

Q	W	E	R	T	Y	U	P	E	T	E	C	A
P	E	T	E	C	A	I	O	P	A	S	D	F
G	H	J	K	P	E	T	E	C	A	L	Z	X
C	P	E	T	E	C	A	V	B	N	M	Q	A
Z	W	S	P	E	T	E	C	A	X	E	D	C
R	F	V	T	G	B	P	E	T	E	C	A	Y
H	N	P	E	T	E	C	A	U	J	M	I	K
O	L	P	M	N	P	E	T	E	C	A	B	V

QUANTAS VEZES A PALAVRA PETECA APARECEU?





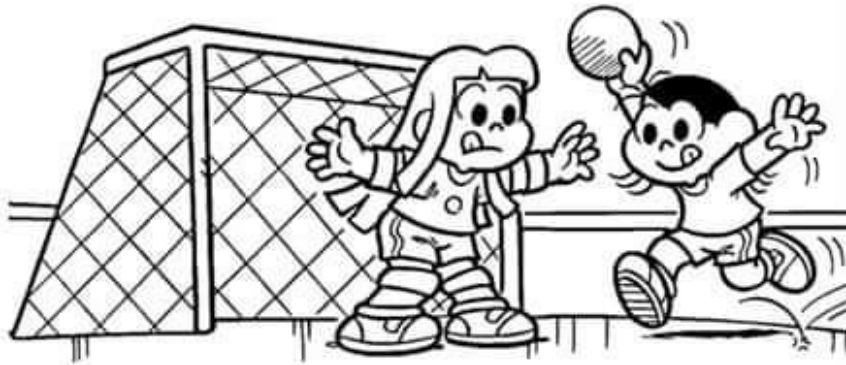

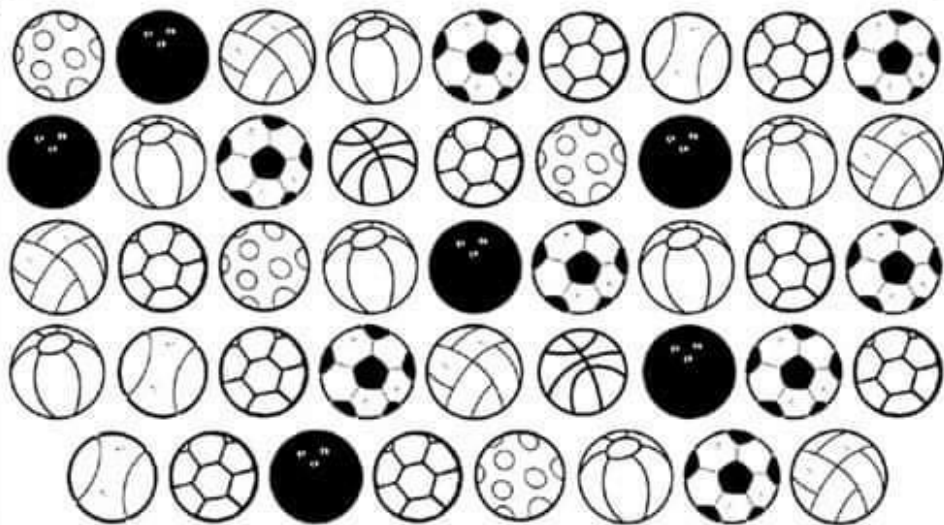

# HANDEBOL

"SALTAR E FAZER GOL... COM A MÃO."



VAMOS CONTAR AS BOLAS!



# BOXE

"SE ESQUIVAR... E ACERTAR UM GOLPE"

VAMOS PINTAR O CAMINHO QUE TEM APENAS LETRAS PARA DESCOBRIR QUEM GANHOU A LUTA DE BOXE!

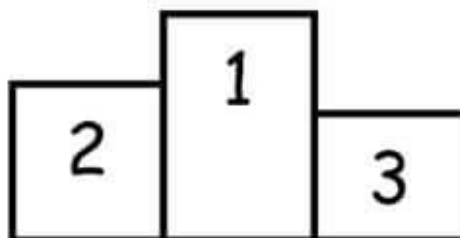
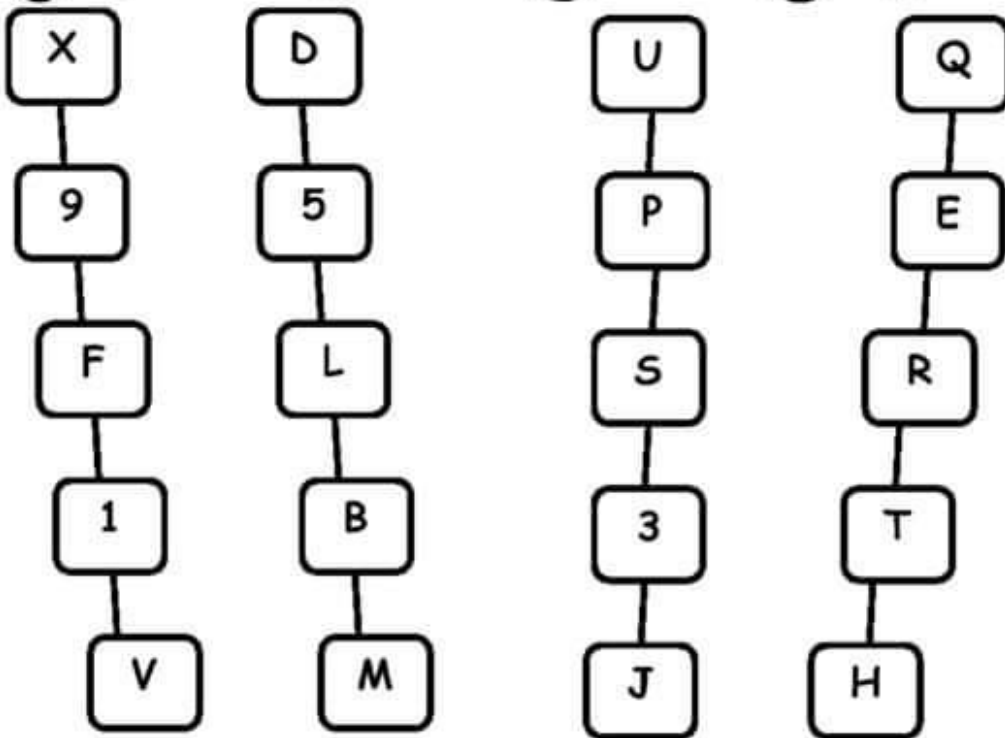

O CAMPEÃO FOI \_\_\_\_\_.











# BASQUETE

"COM PRECISÃO, COLOCAR A BOLA NA CESTA."

VAMOS PINTAR AS BOLAS!



3	
5	
7	
9	
1	
4	
8	
6	
2	

# ESGRIMA

"USAR A ESPADA, DE MANEIRA BEM ELEGANTE."



A MÔNICA QUER VER O CASCAÃO E O  
CEBOLINHA JOGAR ESGRIMA. VAMOS  
AJUDÁ-LA?

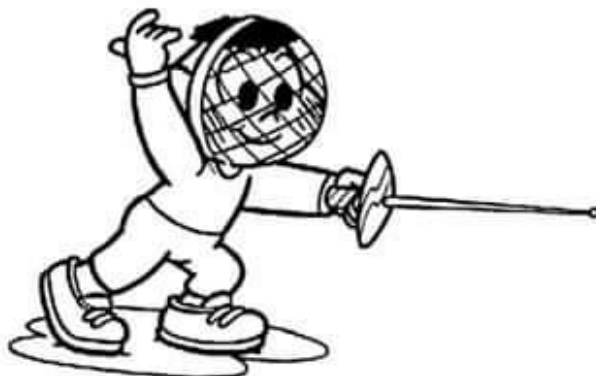
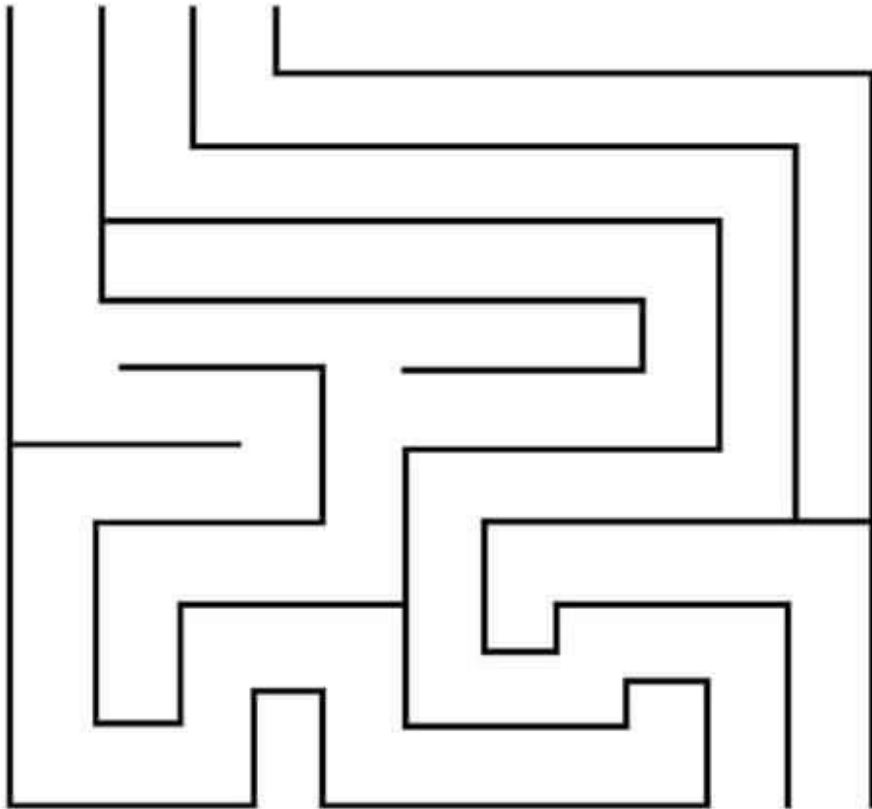

# CANOAGEM



VAMOS CIRCULAR AS FIGURAS QUE INICIAM  
COM A MESMA SÍLABA DA PALAVRA CANOAGEM.

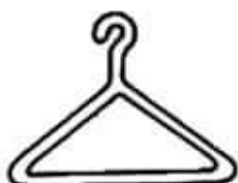

# FUTEBOL

"DRIBLAR E FAZER UM... GOOOOOOL."



O CASÇÃO VAI JOGAR FUTEBOL COM SUA TURMA NO CAMPINHO. VAMOS AJUDÁ-LO A ENCONTRAR SEUS AMIGOS SEGUINDO A TRILHA DO ALFABETO

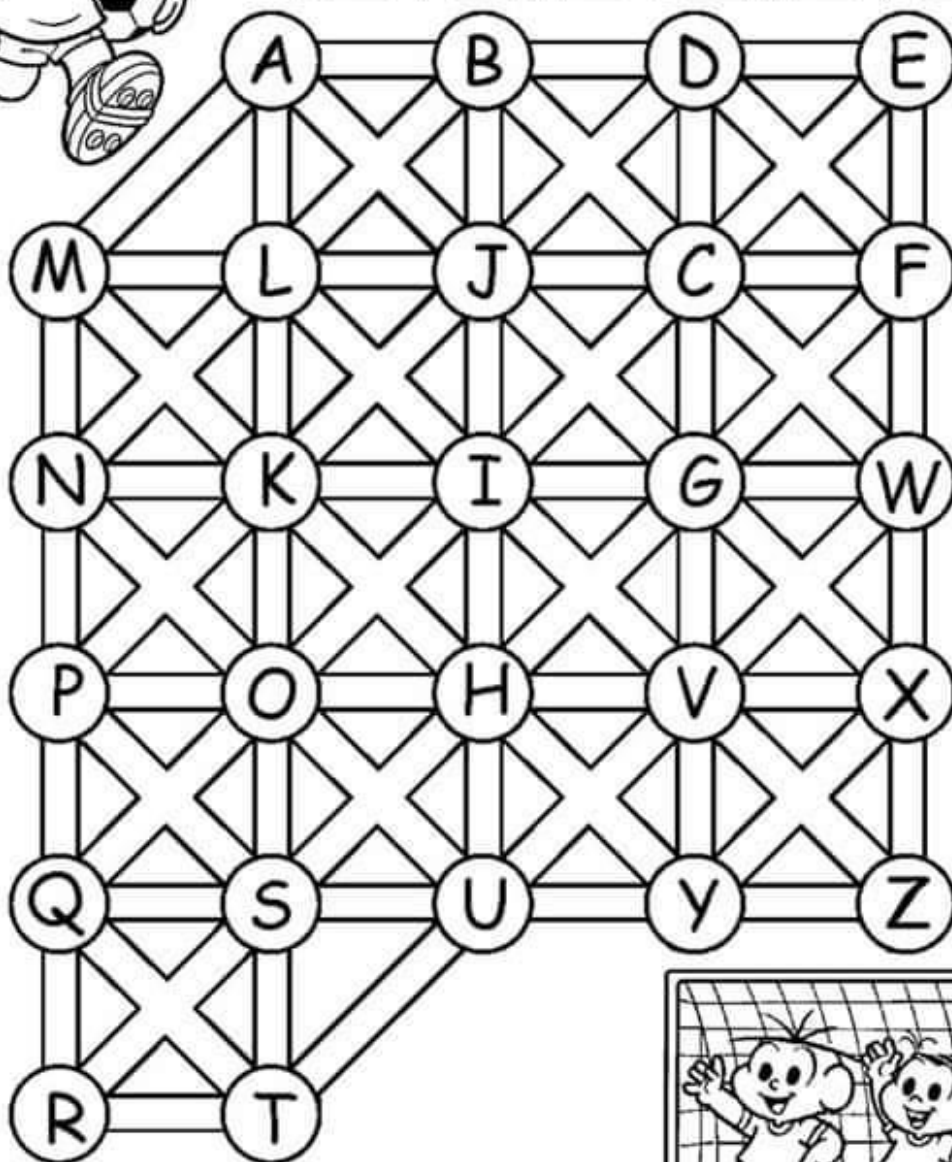

# TRIATLO

"NADAR... PEDALAR... E AINDA CORRER... UFA!"

TRIATLO É UM ESPORTE QUE REÚNE TRÊS MODALIDADES ESPORTIVAS. VAMOS COMPLETAR O NOME DE CADA UMA DELAS, USANDO SOMENTE VOGAIS.

N        T        Ç        ~  
\_\_\_\_    \_\_\_\_    \_\_\_\_

C        C    L        S    M  
\_\_\_\_    \_\_\_\_    \_\_\_\_

C        R    R        D  
\_\_\_\_    \_\_\_\_    \_\_\_\_

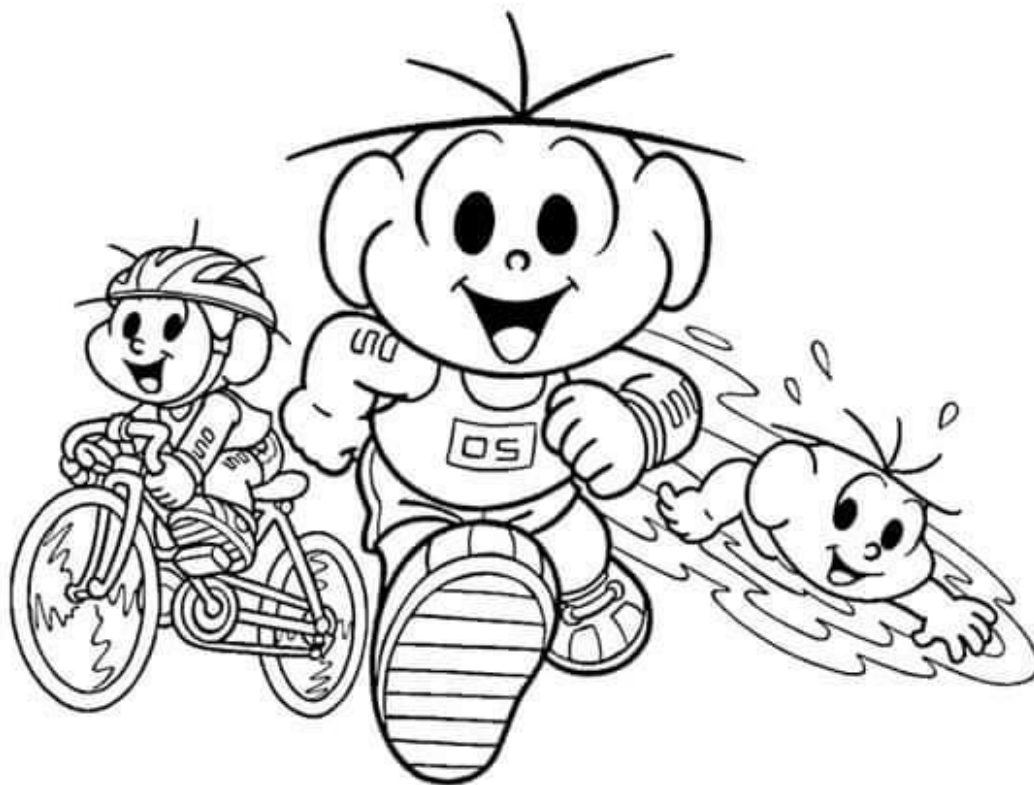

# CICLISMO

"PEDALAR MUITO... USANDO UM CAPACETE SUPERDIFERENTE!"



VAMOS AJUDAR O CASÇÃO A  
CHEGAR ATÉ O FINAL DA PROVA!

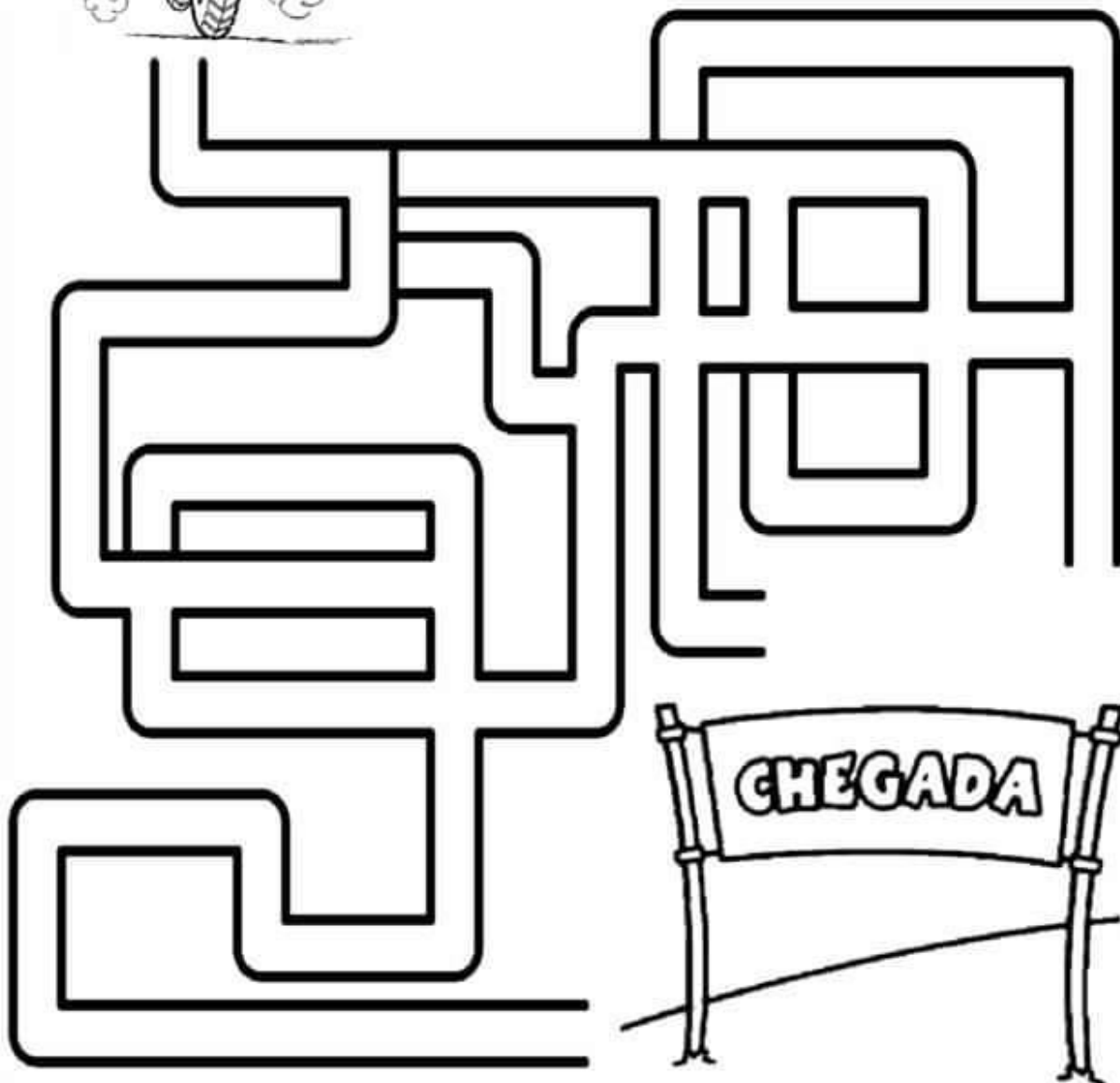

NOME: \_\_\_\_\_

DATA: \_\_\_ / \_\_\_ / \_\_\_

## COMPLETE A SEQUÊNCIA NUMÉRICA



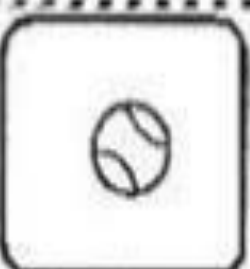
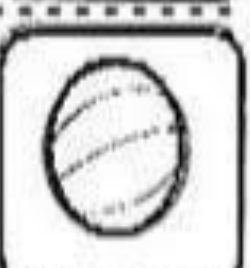



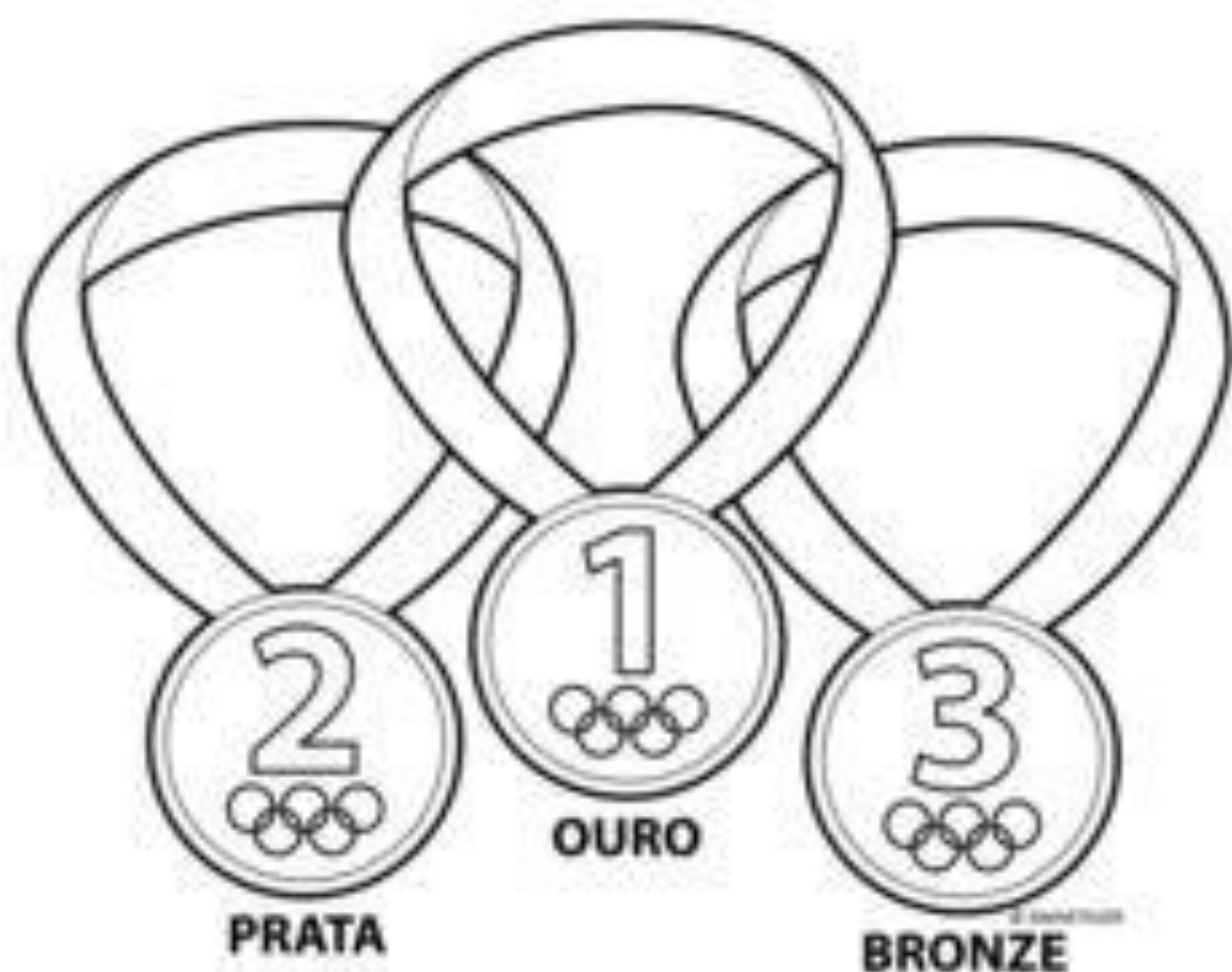

# MEDALHAS OLÍMPICAS

NOME: \_\_\_\_\_ TURMA: \_\_\_\_\_

DATA: \_\_\_\_/\_\_\_\_/\_\_\_\_



# TÊNIS

"CORRER DE UM LADO PARA O OUTRO PARA REBATER A BOLA."

VAMOS LIGAR CADA  
PERSONAGEM À SUA SOMBRÀ



# TREINANDO A COORDENAÇÃO MOTORA E O ALFABETO.



A



ABELHA

B



BOLA

C



CAVALO

D



DADO

E



ELEFANTE

F



FOCA

G



GATO

H



HARPA

I



IGREJA

J



JACARÉ

K



KIWI

L



LEÃO

M



MACACO

N



NAVIO

O



OVO

P



PATO

Q



QUEIJO

R



RATO

S



SAPO

T



TATU



U



UVA

V



VACA

X



XÍCARA

W



WAFFER

Y



YAKULT

Z



ZEBRA

NOME \_\_\_\_\_

## Encontrando os números!

LIGUE OS NÚMEROS QUE CORRESPONDEM A QUANTIDADE DE DEDOS DAS MÃOS INDICADAS:



2

1

4

3

5

NOME:

## SORVETE NUMÉRICO



Pinte os sorvetes, depois recorte-os, e cole na ordem numerica de 1 ao 10 sobre as casquinhas:

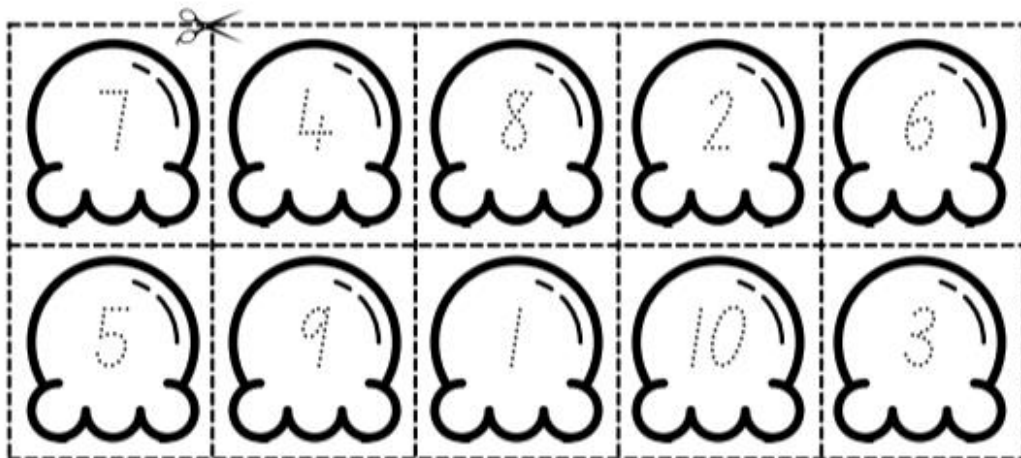

**DESENHE A QUANTIDADE DE SAPINHOS  
CORRESPONDENTES A SUA IDADE!!!**

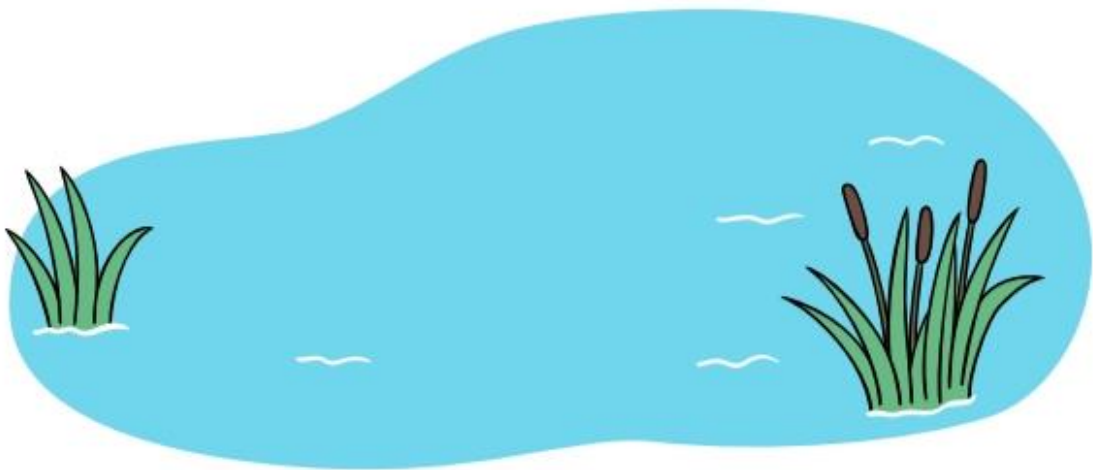

**EU TENHO \_ ANOS DE IDADE!**



[www.smartkids.com.br](http://www.smartkids.com.br)

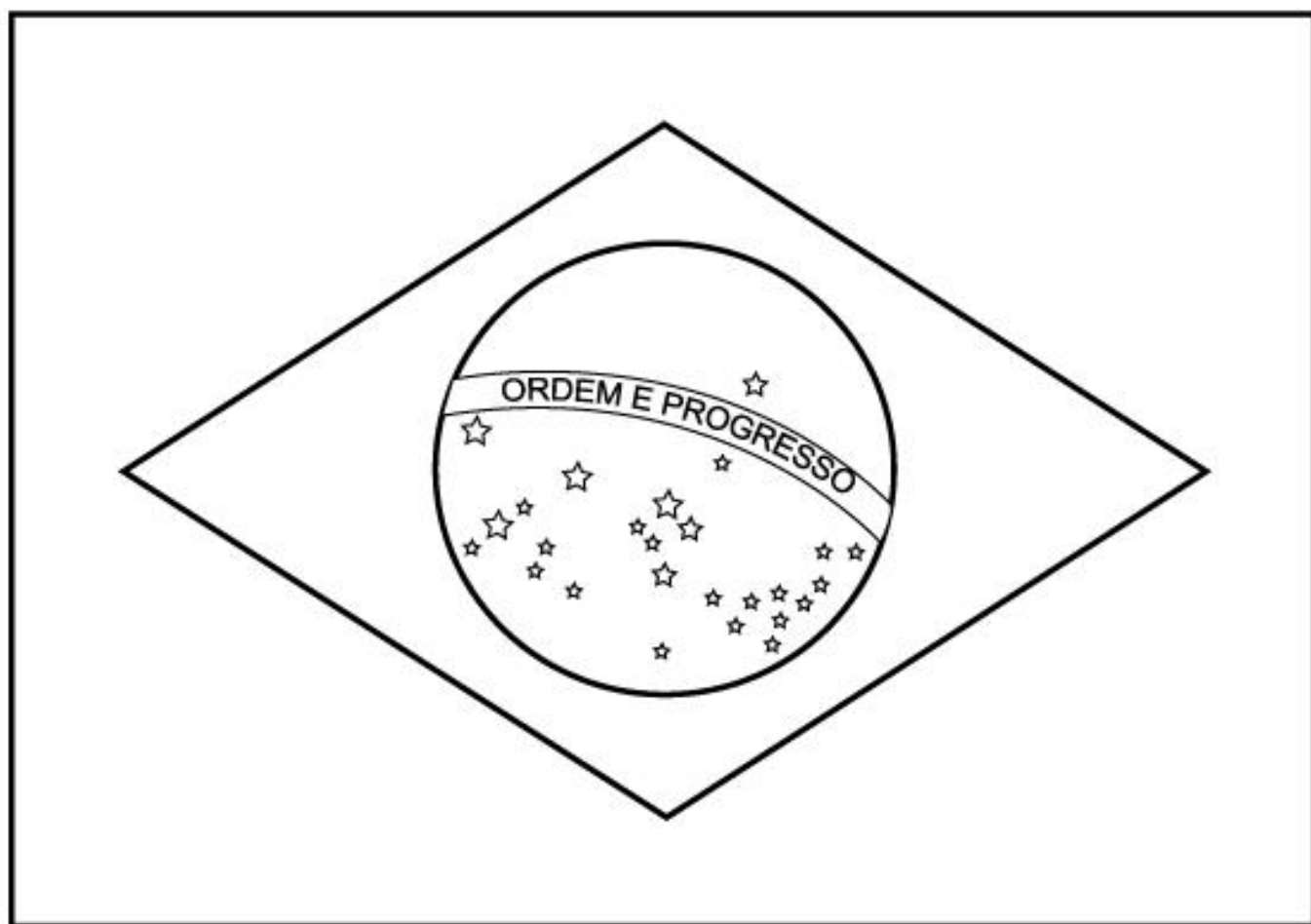

# BANDEIRA DO BRASIL