



PREFEITURA DA ESTÂNCIA TURÍSTICA DE IBIÚNA
EM PROF. CALIL RAHAL NETO

Rua Projetada, 620 - Capim Azedo - Ibiúna - SP - Telefone: 3241-5917



9^a. APOSTILA DE ESTUDOS ATIVIDADES NÃO PRESENCIAIS 3º BIMESTRE



ENSINO FUNDAMENTAL

ALUNO:

PROFESSORA: SIMONE PROENÇA

TURMA: 1º ANO A

DATA DE DEVOLUÇÃO: 30/08/2021

E. M. "PROF. CALIL RAHAL NETO".

NOME: _____

PROFESSORA: SIMONE

TURMA: 1º ANO A

DATA: 09/08/2021



ATIVIDADE 1:

HISTÓRIA

11 DE AGOSTO - DIA DO ESTUDANTE

O DIA DO ESTUDANTE É UMA DATA ESPECIAL, POIS É UMA HOMENAGEM A TODAS AS PESSOAS QUE VALORIZAM O CONHECIMENTO E O CRESCIMENTO PESSOAL. É COMEMORADO EM 11 DE AGOSTO PORQUE ESTA É A DATA EM QUE FORAM CRIADOS OS DOIS PRIMEIROS CURSOS DE NÍVEL SUPERIOR NO PAÍS: CIÊNCIAS JURÍDICAS E CIÊNCIAS SOCIAIS.

CONTE E REGISTRE:



MAÇÃS _____
LÁPIS _____

E. M. "PROF. CALIL RAHAL NETO".

NOME: _____

PROFESSORA: SIMONE TURMA: 1º ANO A DATA: 09/08/2021



ATIVIDADE 2:

LÍNGUA PORTUGUESA

PINTE SOMENTE OS MATERIAIS ESCOLARES.

ESCREVA A PRIMEIRA LETRA DO NOME DE CADA UM DOS DESENHOS.

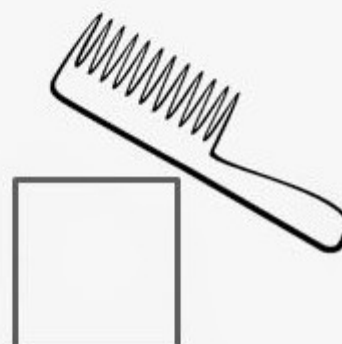
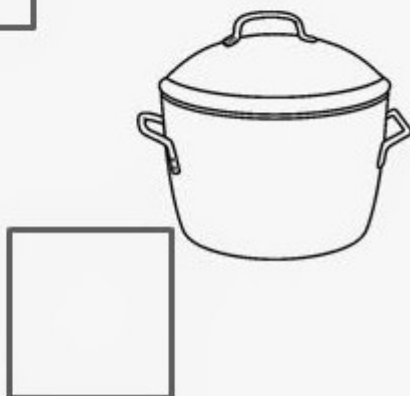
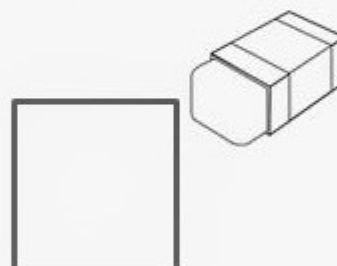
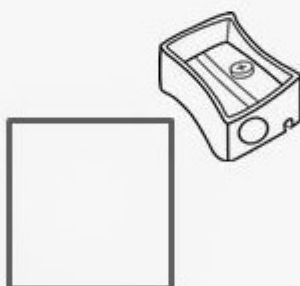
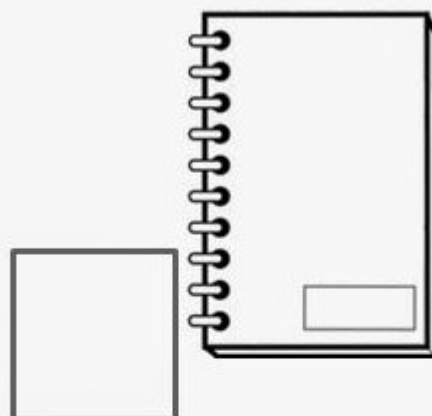
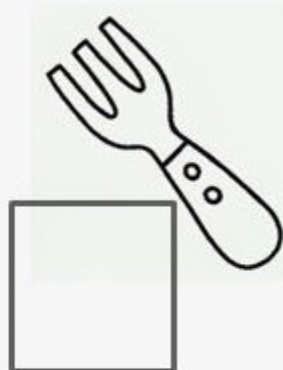
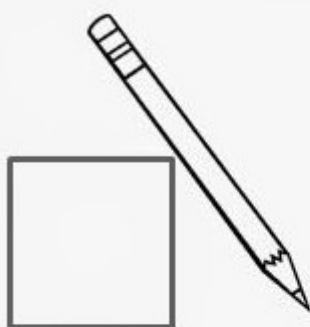

E. M. "PROF. CALIL RAHAL NETO".

NOME: _____

PROFESSORA: SIMONE

TURMA: 1º ANO A

DATA: 10/08/2021



ATIVIDADE 1:

GEOGRAFIA

NA FRENTE DA ESCOLA FICA O GUARDA. ELE AJUDA AS CRIANÇAS A ATRAVESSAREM A RUA.

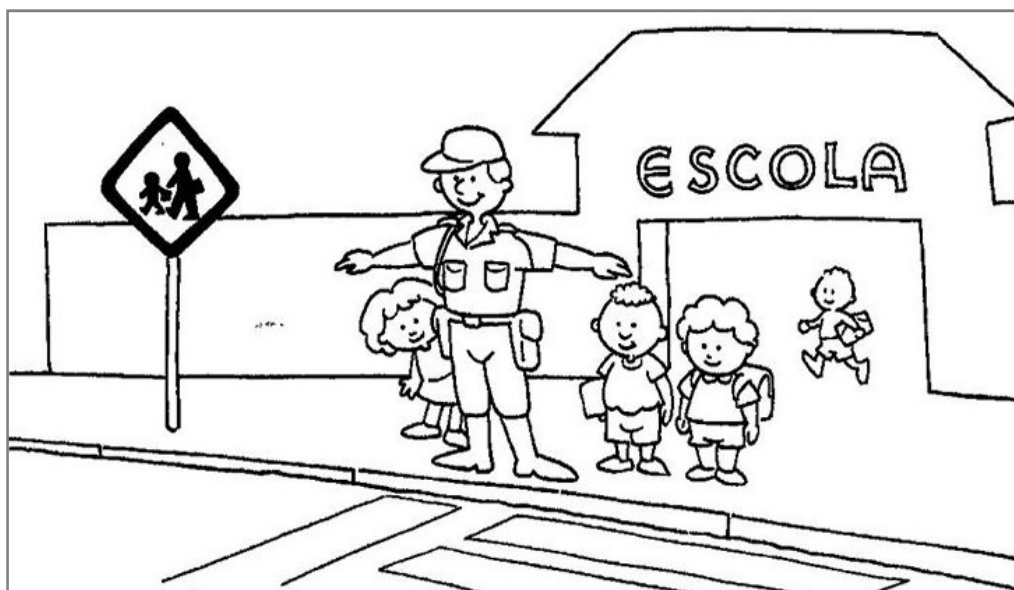

FAIXAS DE PEDESTRES

SÃO LISTRAS BRANCAS PINTADAS NO CHÃO. SÓ DEVEMOS ATRAVESSAR AS RUAS PELAS FAIXAS DE SEGURANÇA.

PINTE AS FAIXAS DE SEGURANÇA ABAIXO DE AMARELO:



E. M. "PROF. CALIL RAHAL NETO".

NOME: _____

PROFESSORA: SIMONE

TURMA: 1º ANO A

DATA: 10/08/2021



ATIVIDADE 2:

MATEMÁTICA

COMPLETE A SEQUÊNCIA

A sequence of 10 numbered cards arranged in a curve. The cards contain the numbers 5, 7, 9, 3, 1. There are 5 blank cards in the sequence. A cartoon boy is sitting at a desk with a school bag, holding a card with 'abc' and '123' written on it.

E. M. "PROF. CALIL RAHAL NETO".

NOME: _____

PROFESSORA: SIMONE TURMA: 1º ANO A DATA: 11/08/2021



ATIVIDADE 1:

CIÊNCIAS

TODOS NÓS SABEMOS DA IMPORTÂNCIA DO USO DAS MÁSCARAS PARA A PROTEÇÃO CONTRA O COVID-19. INCLUSIVE, SEU USO SERÁ INDISPENSÁVEL TAMBÉM NA ESCOLA! SABENDO DISSO, VAMOS AJUDAR A NOSSA PERSONAGEM A COLOCAR SUA MÁSCARA? NÃO SE ESQUEÇA DE DECORAR E COLORIR PARA DEIXÁ-LA BEM BONITA!

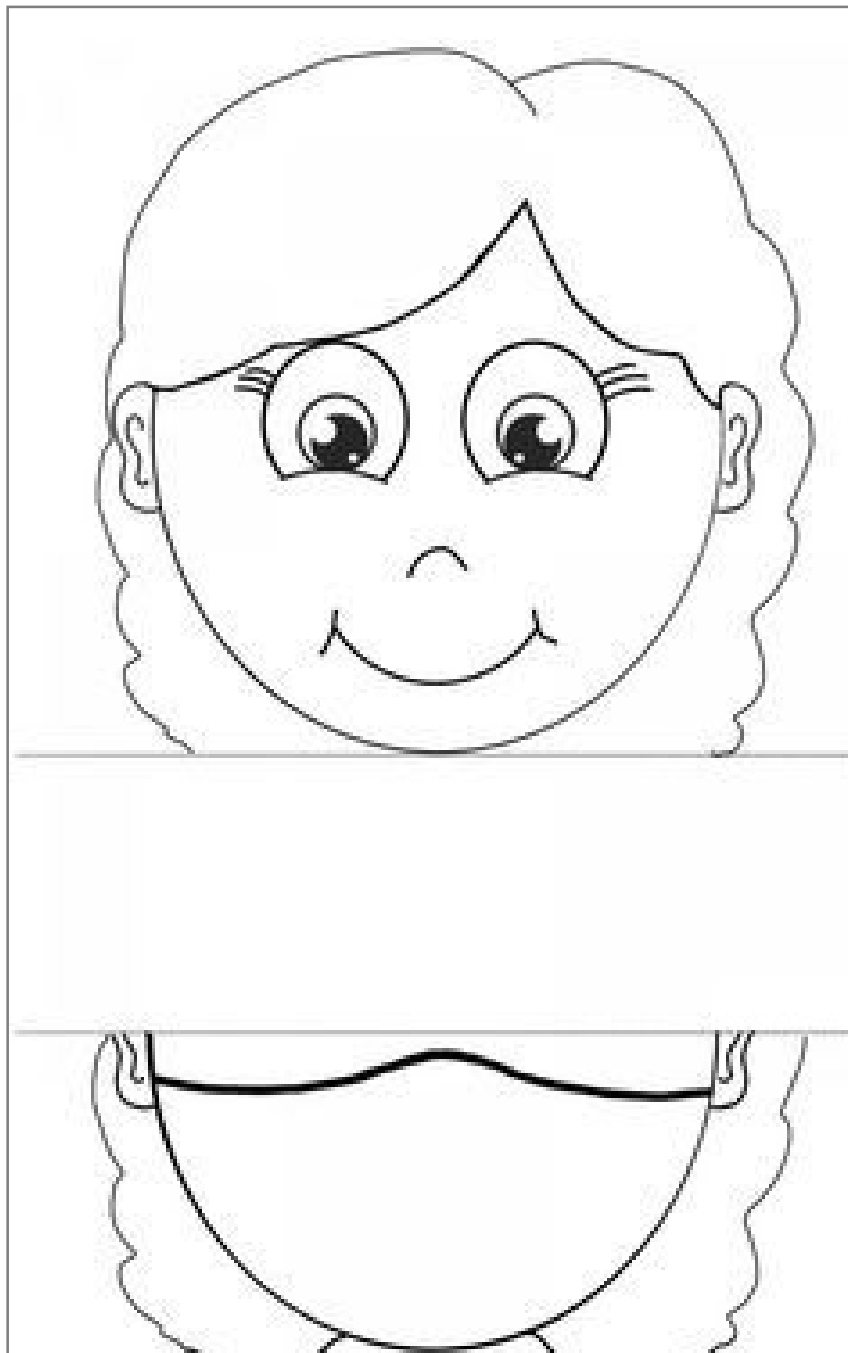

E. M. "PROF. CALIL RAHAL NETO".

NOME: _____

PROFESSORA: SIMONE TURMA: 1º ANO A DATA: 11/08/2021



ATIVIDADE 1:

CIÊNCIAS

TODOS NÓS SABEMOS DA IMPORTÂNCIA DO USO DAS MÁSCARAS PARA A PROTEÇÃO CONTRA O COVID-19. INCLUSIVE, SEU USO SERÁ INDISPENSÁVEL TAMBÉM NA ESCOLA! SABENDO DISSO, VAMOS AJUDAR A NOSSA PERSONAGEM A COLOCAR SUA MÁSCARA? NÃO SE ESQUEÇA DE DECORAR E COLORIR PARA DEIXÁ-LA BEM BONITA!

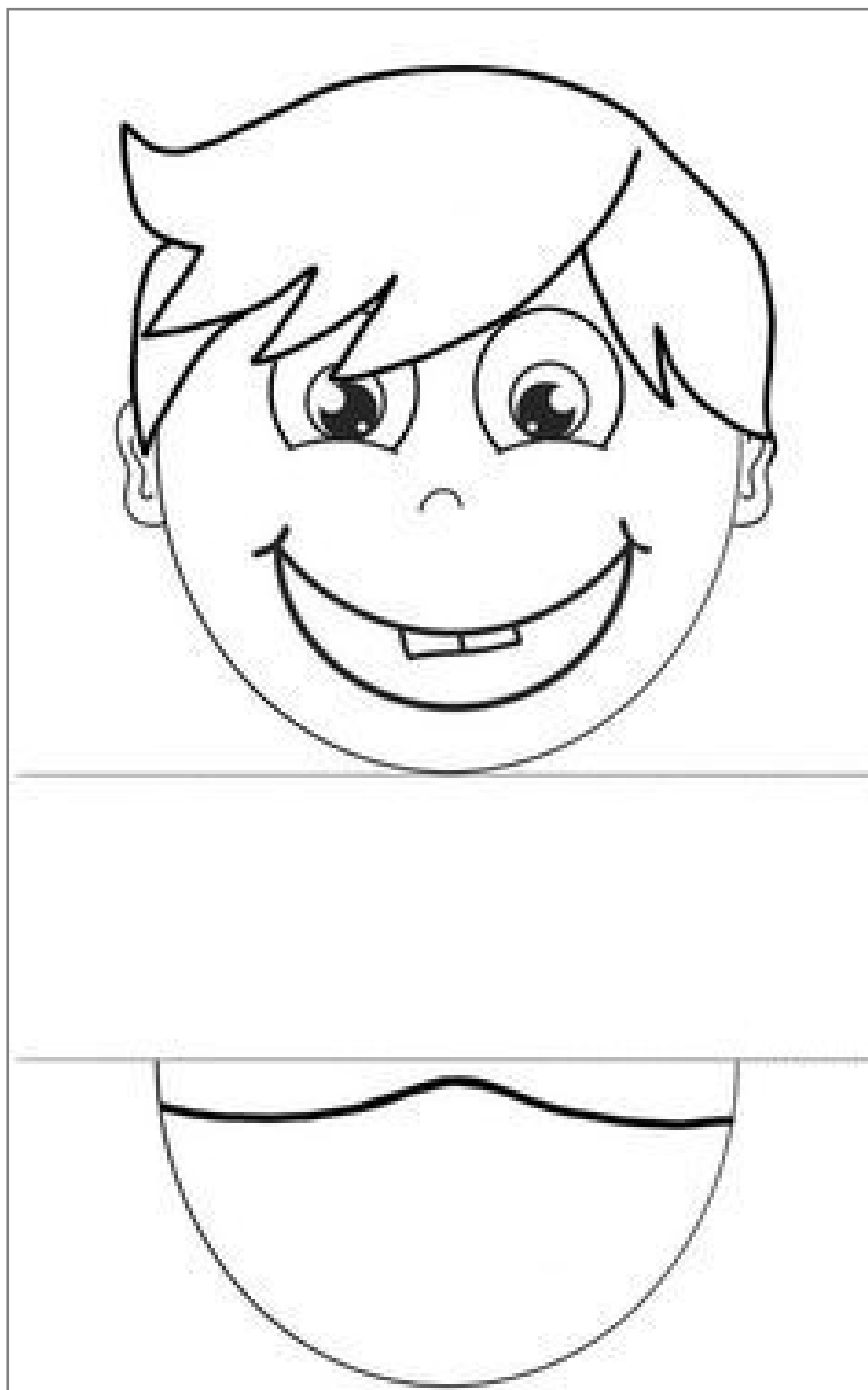

E. M. "PROF. CALIL RAHAL NETO".

NOME: _____

PROFESSORA: SIMONE TURMA: 1º ANO A DATA: 11/08/2021



ATIVIDADE 2:

LÍNGUA PORTUGUESA



MARQUE UM X NA RESPOSTA CORRETA,
DEPOIS PINTE OS OBJETOS



- CANETA
- MOCHILA
- RÉGUA

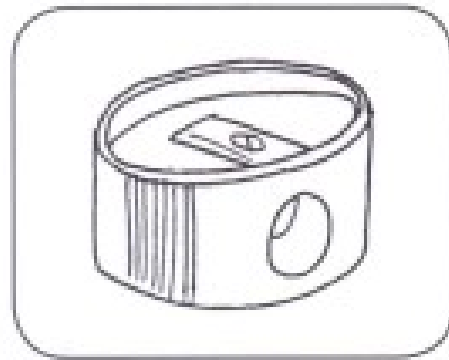

- BORRACHA
- LÁPIS
- APONTADOR

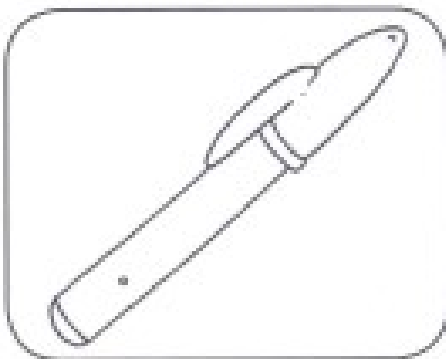

- CANETA
- LÁPIS
- LIVRO

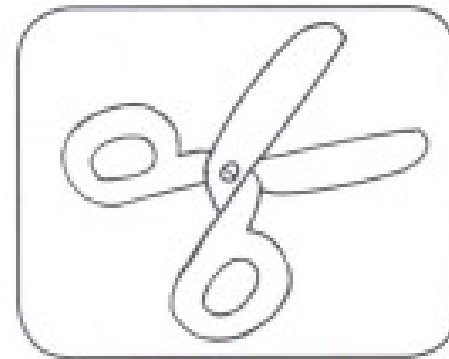

- TESOURA
- CADERNO
- BORRACHA

E. M. "PROF. CALIL RAHAL NETO".

NOME: _____

PROFESSORA: SIMONE TURMA: 1º ANO A DATA: 12/08/2021



ATIVIDADE 1:

MATEMÁTICA

1. CIRCULE OS OBJETOS QUE GERALMENTE OS ESTUDANTES NÃO USAM PARA ESTUDAR NA SALA DE AULA:

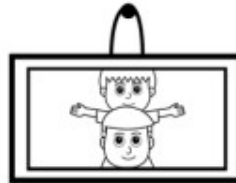
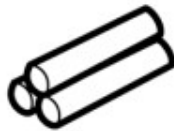
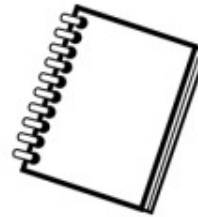

2) PINTE DE AMARELO O LIVRO MAIOR E CIRCULE O MENOR:

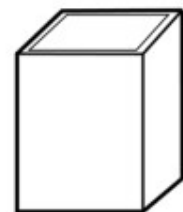
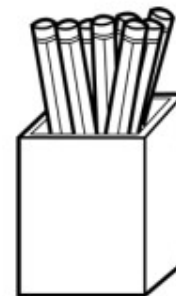

3) PINTE O PORTA-LÁPIS QUE ESTÁ CHEIO

3) QUANTAS MOCHILAS APARECEM?



MOCHILAS

E. M. "PROF. CALIL RAHAL NETO".

NOME: _____

PROFESSORA: SIMONE TURMA: 1º ANO A DATA: 12/08/2021



ATIVIDADE 2:

LÍNGUA PORTUGUESA

1. VAMOS ESCREVER OS NOMES DOS MATERIAIS ESCOLARES?

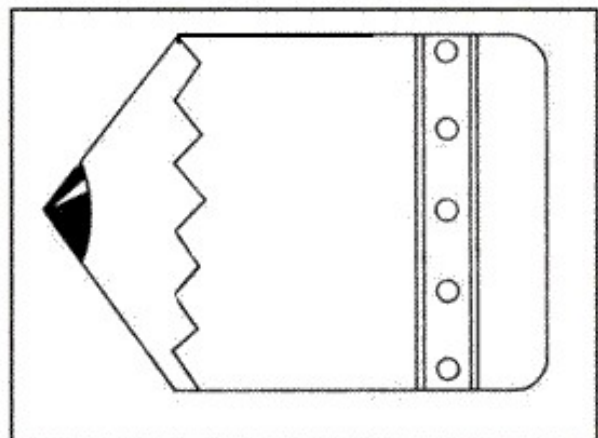
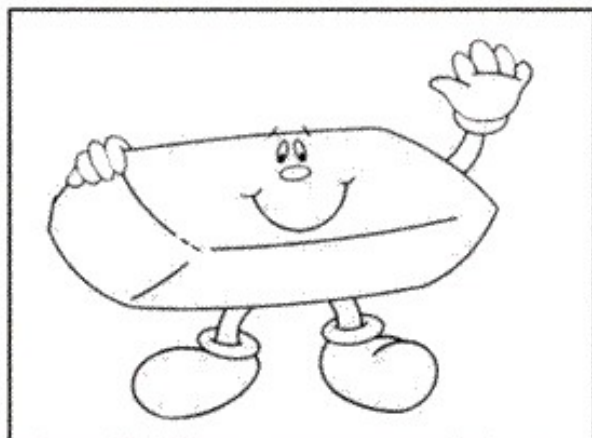
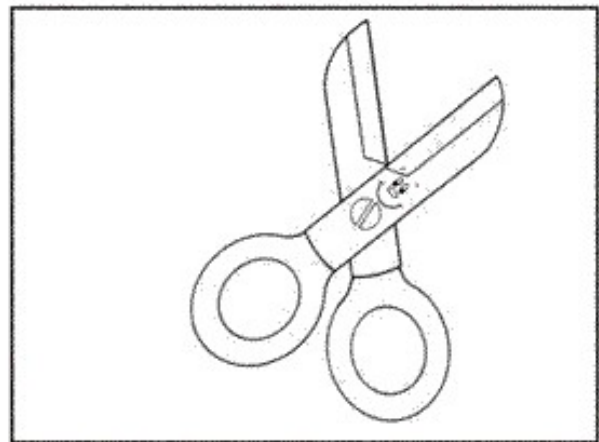
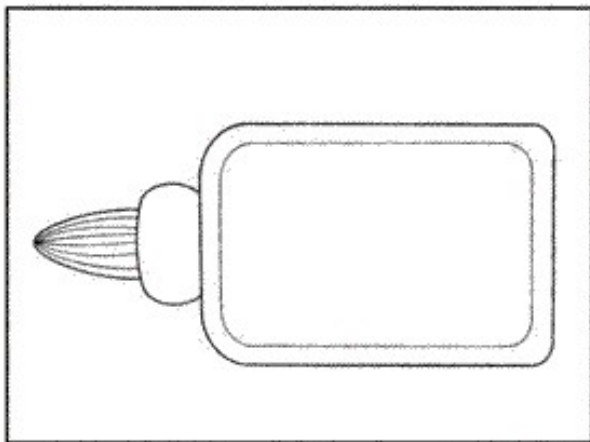

E. M. "PROF. CALIL RAHAL NETO".

NOME: _____

PROFESSORA: SIMONE TURMA: 1º ANO A DATA: 13/08/2021



**ATIVIDADE 1:
MATEMÁTICA
SISTEMA MONETÁRIO**



O DINHEIRO QUE USAMOS

É PRECISO TER DINHEIRO PARA SE COMPRAR ALGUMA COISA. NO BRASIL, A MOEDA QUE USAMOS É O **REAL**.

O SÍMBOLO DO REAL É O **R\$**.

- OBSERVE AS MOEDAS E SEUS VALORES:



- AGORA, OBSERVE AS CÉDULAS:



MICKEY COMPROU UMAS FLORES PARA SUA NAMORADA E O RAMALHETE CUSTOU R\$ 8,00. QUANTAS MOEDAS DE 1 REAL ELE PRECISOU PARA PAGAR? DESENHE-AS NO ESPAÇO ABAIXO:

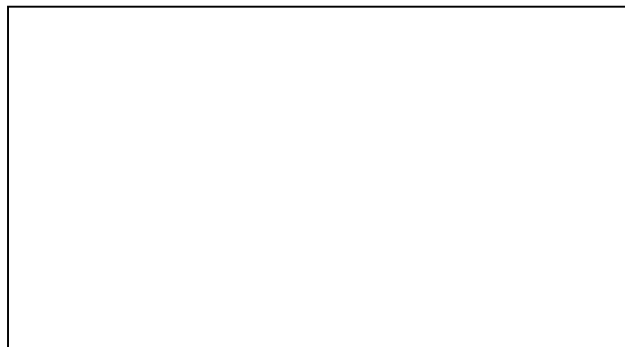

E. M. "PROF. CALIL RAHAL NETO".

NOME: _____

PROFESSORA: SIMONE

TURMA: 1º ANO A

DATA: 13/08/2021



ATIVIDADE 2:

LÍNGUA PORTUGUESA

VEJA OS OBJETOS ESCOLARES NA PRATELEIRA.

A) PINTE TODOS OS OBJETOS ESCOLARES QUE ESTÃO NA PRATELEIRA DO MEIO.

B) CIRCULE AS VOGAIS NO NOME DOS OBJETOS ESCOLARES.

C) FAÇA UM X NO OBJETO QUE TEM O NOME INICIADO PELA CONSOANTE "B".

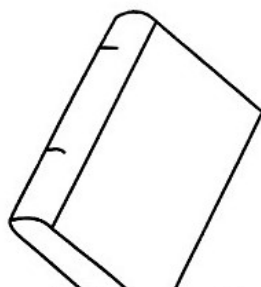

LIVRO

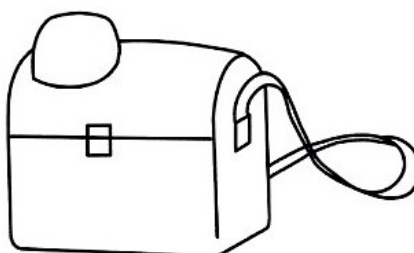

LANCHEIRA

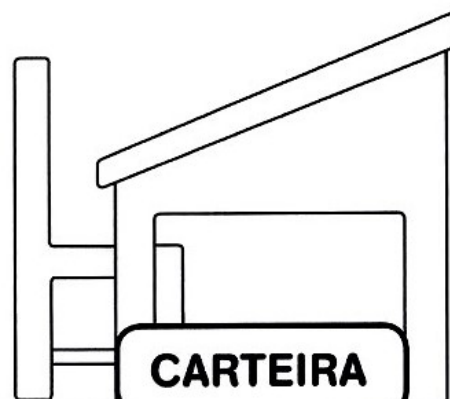

CARTEIRA

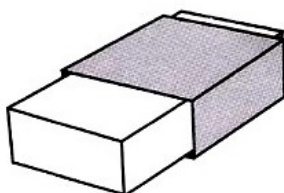

BORRACHA

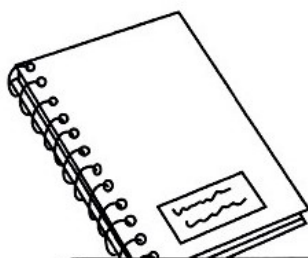

CADERNO

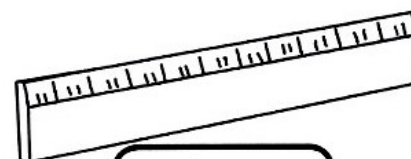

RÉGUA



ESTOJO

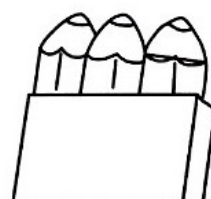

LÁPIS DE COR



CANETA

E. M. "PROF. CALIL RAHAL NETO".

NOME: _____

PROFESSORA: SIMONE TURMA: 1º ANO A DATA: 14/08/2021



ATIVIDADE 1:
MATEMÁTICA

DESCOBRINDO O NUMERAL

1 DESCUBRA, NO QUADRO, OS NUMERAIS QUE ESTARIAM NO LUGAR DOS SÍMBOLOS E ESCREVA-OS ABAIXO.

1	2	3		5	6	7	
9	10	11	12		14	15	16
	18	19		21	22	23	
25		27	28	29		31	32
33	34		36	37	38		40



E. M. "PROF. CALIL RAHAL NETO".

NOME: _____

PROFESSORA: SIMONE

TURMA: 1º ANO A

DATA: 14/08/2021



ATIVIDADE 2:

ARTE

VICENTE VAN GOGH

VAN GOGH NASCEU NA HOLANDA EM 1853 E VIVEU POR 37 ANOS. ARTISTA PÓS-IMPRESSIONISTA, CARACTERIZOU-SE PELA SUA GRANDE EXPRESSIVIDADE ARTÍSTICA.

PINTOU OS MAIS VARIADOS TEMAS ARTÍSTICOS: FLORES, PAISAGENS, PESSOAS, NOITES ESTRELADAS, CAMPOS COM TRIGO E OUTROS.

APESAR DA CURTA CARREIRA DE APROXIMADAMENTE 10 ANOS, O ARTISTA PRODUZIU APROXIMADAMENTE 700 QUADROS. VAN GOGH DIZIA: "EU NÃO QUERO PINTAR QUADROS, EU QUERO PINTAR A VIDA".

DURANTE SUA VIDA, VENDEU APENAS UM QUADRO. SEU MÉRITO FOI RECONHECIDO APÓS A SUA MORTE.

VAMOS CONHECER UM DOS SEUS QUADROS: "O ESCOLAR", DE 1888.

AGORA, VOCÊ É O ARTISTA! INSPIRE-SE EM VAN GOGH E FAÇA UMA PINTURA BEM CAPRICHADA COM A TÉCNICA QUE MAIS GOSTA.



E. M. "PROF. CALIL RAHAL NETO".

NOME: _____

PROFESSORA: SIMONE TURMA: 1º ANO A DATA: 16/08/2021



ATIVIDADE 1: HISTÓRIA

AGOSTO: MÊS DO FOLCLORE

O FOLCLORE EM NOSSO PAÍS É COMEMORADO DESDE 1965, QUANDO UM DECRETO FEDERAL OFICIALIZOU ESTA DATA.

FOLCLORE É O CONJUNTO DA CULTURA POPULAR QUE ENVOLVE A SABEDORIA E A LINGUAGEM DO POVO; É DINÂMICO, POIS SE TRANSFORMA À MEDIDA QUE EVOLUI A CRIATIVIDADE DO HOMEM.

SEGUNDO ALGUNS ESTUDIOSOS, O FOLCLORE SE MANIFESTA EM DIVERSOS CAMPOS ATRAVÉS DE: DANÇAS, MÚSICAS, ADIVINHAÇÕES, PROVÉRBIOS, SUPERTIÇÕES E CRENDICES, ARTESANATO, BRINQUEDOS, COSTUMES, LENDAS, COMIDAS, BEBIDAS, FESTAS, JOGOS... TUDO O QUE FAZ PARTE DA CULTURA E MEMÓRIA DE UM POVO. É UTILIZADO PELO POVO DE CADA LUGAR PARA AJUDÁ-LO A COMPREENDER AS ATITUDES E O MODO DE VIDA DO GRUPO A QUE PERTENCEM, SENDO VARIÁVEL DE REGIÃO PARA REGIÃO.

O NOSSO FOLCLORE BRASILEIRO É CONSIDERADO UM DOS MAIS RICOS DO MUNDO, E RECEBEU A INFLUÊNCIA DOS ÍNDIOS, BRANCOS E NEGROS.

CADA REGIÃO DO BRASIL EXPRESSA DE FORMA BASTANTE CLARA AS SUAS TRADIÇÕES FOLCLÓRICAS.

ATIVIDADE

LEIA AS PISTAS E CIRCULE A RESPOSTA DA ADIVINHA.

TEM PELOS.

QUATRO PATAS.

ANIMAL DOMÉSTICO.

LATE.



E. M. "PROF. CALIL RAHAL NETO".

NOME: _____

PROFESSORA: SIMONE TURMA: 1º ANO A DATA: 16/08/2021



ATIVIDADE 2: MATEMÁTICA

O QUE SÃO PARLENDAS?

SÃO VERSINHOS COM TEMÁTICA INFANTIL. POSSUEM UMA RIMA FÁCIL E SÃO MUITO POPULARES ENTRE AS CRIANÇAS. NÃO SÃO CANTADAS, SÃO RECITADAS PARA ENTENDER, MEMORIZAR, ACALMAR E DIVERTIR AS CRIANÇAS.



COMPLETE A PARLENDA COM O NUMERAL E A QUANTIDADE DE OVOS.

A GALINHA DO VIZINHO
BOTA OVO AMARELINHO

BOTA	1	0
BOTA		
BOTA		
BOTA		
BOTA		
BOTA		
BOTA		
BOTA		
BOTA		
BOTA		



E. M. "PROF. CALIL RAHAL NETO".

NOME: _____

PROFESSORA: SIMONE TURMA: 1º ANO A DATA: 17/08/2021



ATIVIDADE 1: GEOGRAFIA



BRINCADEIRAS FOLCLÓRICAS

1) Use os códigos e relacione às cenas correspondentes.

- ★ Lia, Ane e Carol brincam de pular elástico.
- * Sílvio e Ronaldo jogam bolinhas de gude.
- As irmãs trigêmeas pulam corda.
- ▲ A pipa de Rômulo voa alto.

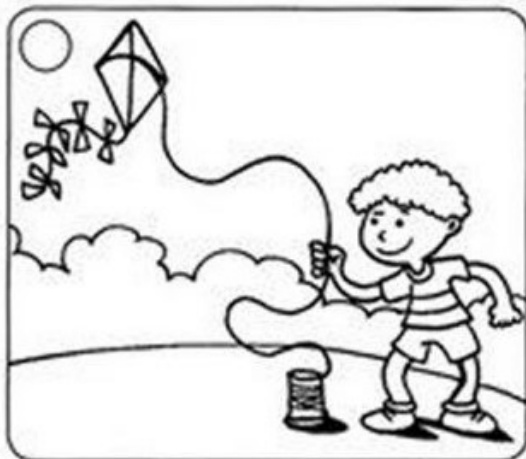
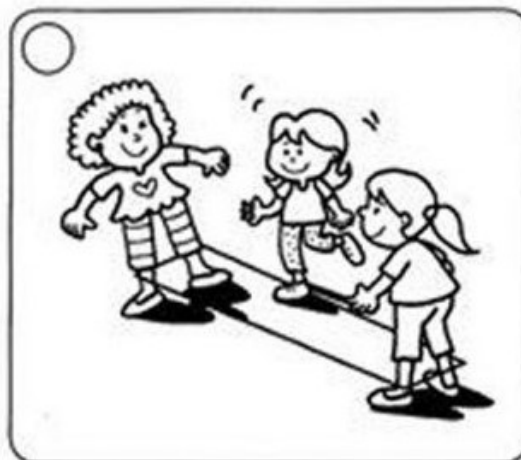
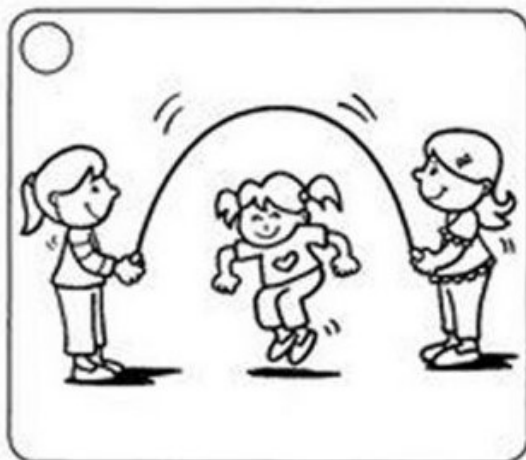

VOCÊ JÁ CONHECIA ALGUMA DESSAS BRINCADEIRAS:

() SIM

() NÃO

E. M. "PROF. CALIL RAHAL NETO".

NOME: _____

PROFESSORA: SIMONE

TURMA: 1º ANO A

DATA: 17/08/2021



ATIVIDADE 2:
LÍNGUA PORTUGUESA

PERALTICES DO SACI

ISABEL CRISTINA SILVEIRA SOARES



A IARA PERDEU O PENTE
DONA CUCA O CALDEIRÃO,
BOITATÁ PERDEU O FOGO
E NÃO HÁ EXPLICAÇÃO!



O BOTO COR-DE-ROSA
NÃO SABIA O QUE FAZER,
MAS ESTAVA TODO PROSA
POIS NÃO TINHA O QUE PERDER!

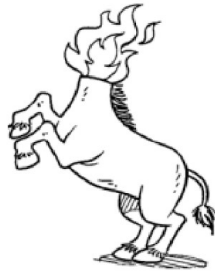

DONA MULA-SEM-CABEÇA
DESCOBRIU E DEU SOCORRO,
ACHOU TODOS OS PERDIDOS
COM O SACI, DENTRO DO GORRO!
QUE MOLEQUE TRAVESSO!



* MARQUE AS RESPOSTAS CORRETAS:

A) QUEM PERDEU O FOGO FOI:

- () A MULA-SEM-CABEÇA
- () O BOTO-COR-DE-ROSA
- () O BOITATÁ

B) DONA CUCA PERDEU O:

- () PENTE
- () CALDEIRÃO
- () GORRO

C) QUEM HAVIA ESCONDIDO OS OBJETOS FOI:

- () O SACI
- () O CURUPIRA
- () A IARA

E. M. "PROF. CALIL RAHAL NETO".

NOME: _____

PROFESSORA: SIMONE TURMA: 1º ANO A DATA: 18/08/2021



ATIVIDADE 1:

CIÊNCIAS

LENDA DO BOTO COR DE ROSA

CONTA A LENDA QUE O BOTO COR DE ROSA VIVE NOS RIOS DA AMAZÔNIA E EM NOITES DE FESTA JUNINA, ELE SE TRANSFORMA EM UM HOMEM BONITO, TODO VESTIDO DE BRANCO, QUE DEIXA AS ÁGUAS EM BUSCA DE ATRAIR AS MOÇAS E CONQUISTÁ-LAS. ANTES DO AMANHECER, ENTRA NO RIO E SE TRANSFORMA DE NOVO EM UM MAMÍFERO DAS ÁGUAS.

O BOTO É UM ANIMAL AQUÁTICO, OU SEJA, QUE VIVE NA ÁGUA. OS ANIMAIS AQU ENCAIXE AS PALAVRAS ABAIXO NA CRUZADINHA E CONHEÇA OUTROS ANIMAIS AQUÁTICOS COMO O BOTO COR DE ROSA:

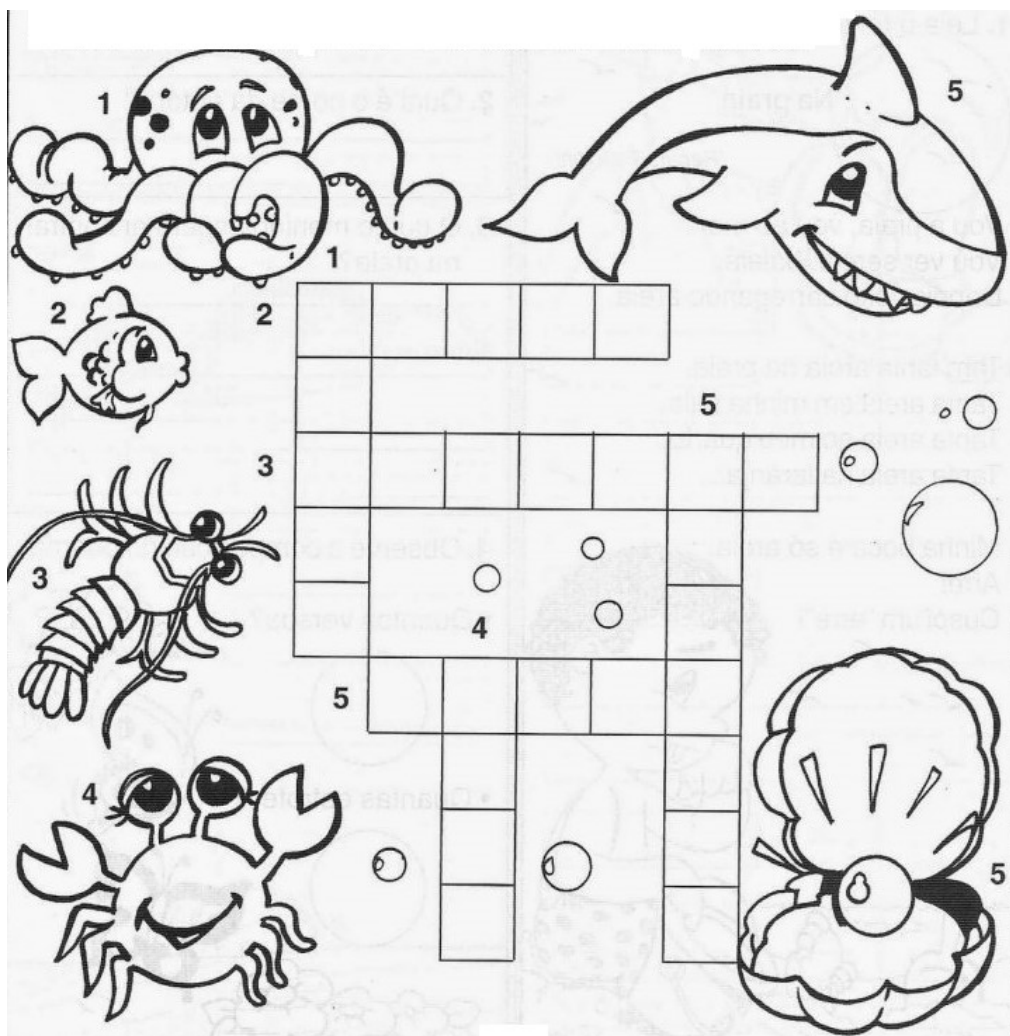

POLVO – PEIXE – LAGOSTA – SIRI – OSTRA - TUBARÃO

E. M. "PROF. CALIL RAHAL NETO".

NOME: _____

PROFESSORA: SIMONE

TURMA: 1º ANO A

DATA: 18/08/2021



**ATIVIDADE 2:
MATEMÁTICA**

AJUDE O SACI

COMPLETE OS NUMERAIS QUE FALTAM PARA O SACI CHEGAR ATÉ O SEU GORRO:

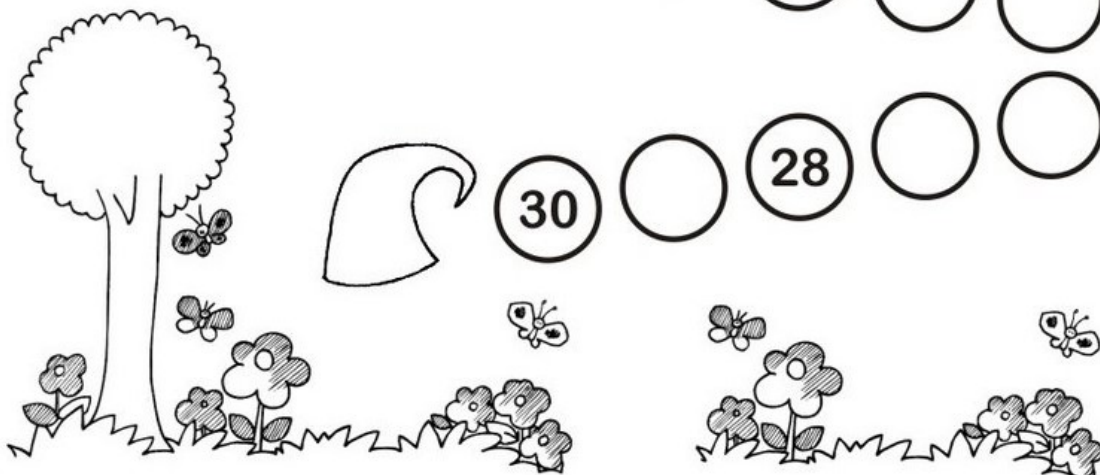
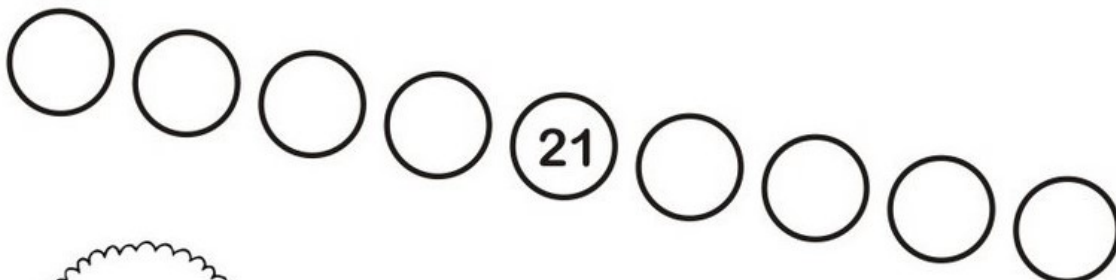
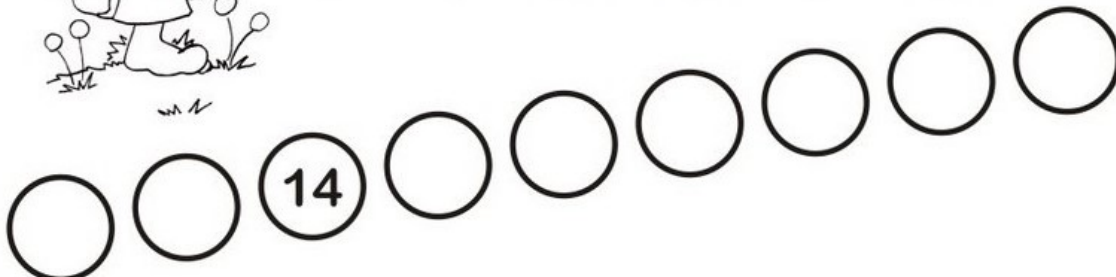

E. M. "PROF. CALIL RAHAL NETO".

NOME: _____

PROFESSORA: SIMONE

TURMA: 1º ANO A

DATA: 19/08/2021



**ATIVIDADE 1:
LÍNGUA PORTUGUESA**

✿ PINTE OS RETÂNGULOS COM OS NOMES CORRETOS.



MULA

UMLA

MLUA



IRAA

AIRA

IARA



RUCUPIRA

CURUPIRA

CUPIRURA



CASI

SACI

SICA

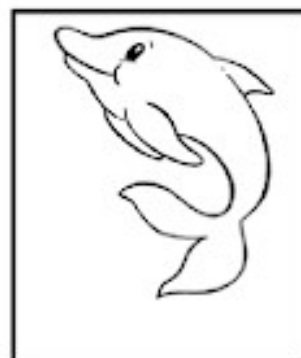

OBTO

TOBO

BOTO

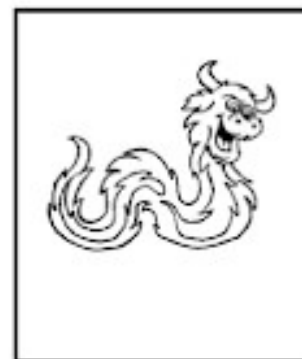

BOTAITÁ

BOITÁTA

BOITATÁ

E. M. "PROF. CALIL RAHAL NETO".

NOME: _____

PROFESSORA: SIMONE TURMA: 1º ANO A DATA: 19/08/2021



ATIVIDADE 2: MATEMÁTICA



VAMOS CONTAR OS PERSONAGENS
DO FOLCLORE!



E. M. "PROF. CALIL RAHAL NETO".

NOME: _____

PROFESSORA: SIMONE TURMA: 1º ANO A DATA: 20/08/2021



**ATIVIDADE 1:
LÍNGUA PORTUGUESA
BRINCADEIRAS**

DITADO RECORTADO – IVAN CRUZ

RECORTE OS NOMES DAS TELAS E COLE-OS NA OBRA CORRESPONDENTE:

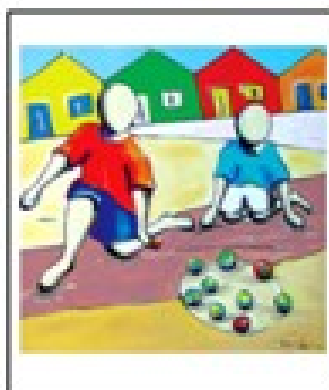

PÉ DE LATA	PIQUE ESCONDE	PATINETE
PULANDO CORDA	BOLA DE GUDE	AVIAOZINHO DE PAPEL

E. M. "PROF. CALIL RAHAL NETO".

NOME: _____

PROFESSORA: SIMONE

TURMA: 1º ANO A

DATA: 20/08/2021



ATIVIDADE 2:

ARTE

JOGO DA MEMÓRIA

PINTAR, RECORTAR E JOGAR O JOGO DA MEMÓRIA SOBRE O FOLCLORE.



SACI

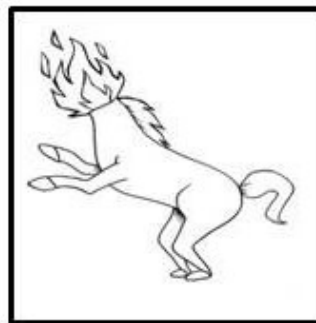

**MULA -
SEM -
CABEÇA**



IARA



CURUPIRA

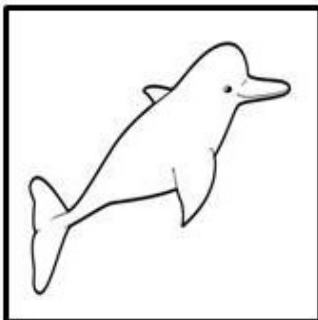

BOTO

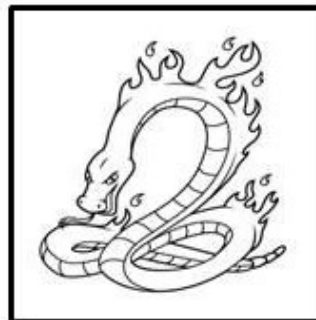

BOITATÁ



**NEGUINHO
DO
PASTOREIO**

E. M. "PROF. CALIL RAHAL NETO".

NOME: _____

PROFESSORA: SIMONE

TURMA: 1º ANO A

DATA: 23/08/2021



**ATIVIDADE 1:
HISTÓRIA
PROVÉRBIOS**

PROVÉRBIOS SÃO DITOS POPULARES (FRASES E EXPRESSÕES) QUE TRANSMITEM CONHECIMENTOS COMUNS SOBRE A VIDA. MUITOS DELES FORAM CRIADOS NA ANTIGUIDADE, PORÉM ESTÃO RELACIONADOS A ASPECTOS UNIVERSAIS DA VIDA, POR ISSO SÃO UTILIZADOS ATÉ OS DIAS ATUAIS. É MUITO COMUM OUVIRMOS PROVÉRBIOS EM SITUAÇÕES DO COTIDIANO.

EXEMPLO:

1) **NÃO DEIXAR A**  **CAIR.**

2) **NÃO DEVEMOS DESISTIR DIANTE DAS DIFICULDADES.**

VAMOS APRENDER COM OS PROVÉRBIOS?

➔ **LIGUE OS PROVÉRBIOS AOS SEUS SIGNIFICADOS**

PROVÉRBIOS

**QUEM NÃO TEM
CÃO, CAÇA COM
GATO.**

**MUITO TROVÃO,
SINAL DE POUCA
CHUVA.**

**DE GRÃO EM
GRÃO, A GALINHA
ENCHE O PAPO.**

SIGNIFICADOS

**DEVAGARINHO,
PODEMOS FAZER
MUITAS COISAS.**

**MUITO BARULHO
NÃO É SINAL DE
SABEDORIA.**

**SABER VIVER COM
O QUE SE TEM.**

E. M. "PROF. CALIL RAHAL NETO".

NOME: _____

PROFESSORA: SIMONE

TURMA: 1º ANO A

DATA: 23/08/2021



**ATIVIDADE 2:
MATEMÁTICA**

VAMOS COMPLETAR OS QUADRADOS COM OS NÚMEROS QUE FALTAM PARA COMPLETAR A PARLENDAS:

FEIJÃO COM ARROZ.

FEIJÃO NO PRATO.

REPITO OUTRA VEZ.

COMER BISCOITO.

COMER PASTÉIS.

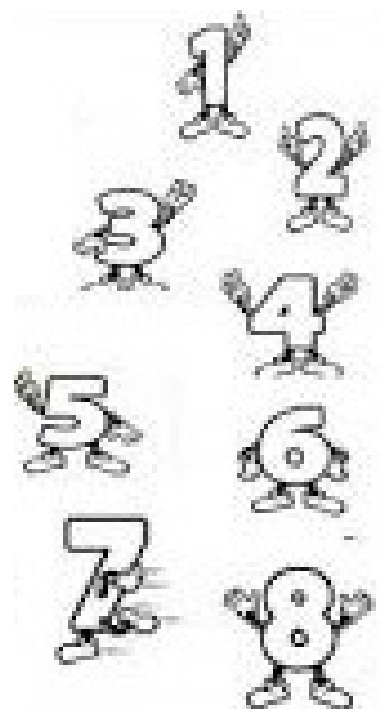

E. M. "PROF. CALIL RAHAL NETO".

NOME: _____

PROFESSORA: SIMONE

TURMA: 1º ANO A

DATA: 24/08/2021



ATIVIDADE 1: GEOGRAFIA

CANTE A MÚSICA E PINTE O GALINHO DE ACORDO COM AS CORES QUE SÃO APRESENTADAS NA MÚSICA.

<p> O MEU GALINHO </p> <p>HÁ TRÊS NOITES QUE EU NÃO DURMO, OLA LÁ! POIS PERDI O MEU GALINHO, OLA LÁ! COITADINHO, OLA LÁ! POBREZINHO, OLA LÁ! EU PERDI LÁ NO JARDIM.</p> <p> ELE É BRANCO E AMARELO, OLA LÁ! TEM A CRISTA VERMELHINHA, OLA LÁ! BATE AS ASAS, OLA LÁ! ABRE O BICO, OLA LÁ! ELE FAZ QUI-RI-QUI-QUI.</p> <p> JÁ RODEI EM MATO GROSSO, OLA LÁ! AMAZONAS E PARÁ, OLA LÁ! ENCONTREI, OLA LÁ! MEU GALINHO, OLA LÁ! NO SERTÃO DO CEARÁ!</p>	
--	---

PINTE NO MAPA ABAIXO OS ESTADOS CITADOS NO TEXTO:

MATO GROSSO

AMAZONAS

CEARÁ



E. M. "PROF. CALIL RAHAL NETO".

NOME: _____

PROFESSORA: SIMONE TURMA: 1º ANO A DATA: 24/08/2021



ATIVIDADE 2:
LÍNGUA PORTUGUESA



VAMOS BRINCAR DE CAÇA-PALAVRAS?



SACI



CURUPIRA



BOITATÁ



IARA



LOBISOMEM

M	A	S	A	C	I	X	I	S	P
N	V	C	U	R	U	P	I	R	A
B	O	I	T	A	T	Á	K	D	I
T	V	I	A	R	A	G	F	D	U
V	L	O	B	I	S	O	M	E	M

E. M. "PROF. CALIL RAHAL NETO".

NOME: _____

PROFESSORA: SIMONE

TURMA: 1º ANO A

DATA: 25/08/2021



ATIVIDADE 1:

CIÊNCIAS

LENDA DA IARA

A IARA É UMA LENDA DO FOLCLORE BRASILEIRO. ELA É UMA LINDA SEREIA QUE VIVE NO RIO AMAZONAS, SUA PELE É MORENA, POSSUI CABELOS LONGOS, NEGROS E OLHOS CASTANHOS.

A IARA COSTUMA TOMAR BANHO NOS RIOS E CANTAR UMA MELODIA IRRESISTÍVEL, DESTA FORMA OS HOMENS QUE A VÊM NÃO CONSEGUEM RESISTIR AOS SEUS DESEJOS E PULAM DENTRO DO RIO. ELA TEM O PODER DE CEGAR QUEM A ADMIRA E LEVAR PARA O FUNDO DO RIO QUALQUER HOMEM QUE ELA DESEJAR SE CASAR.

ESQUEMA CORPORAL

PINTE, RECORTE E MONTE A IARA NA PRÓXIMA PÁGINA. LEMBRE-SE: TODAS AS ETAPAS DEVEM SER FEITAS POR VOCÊ!

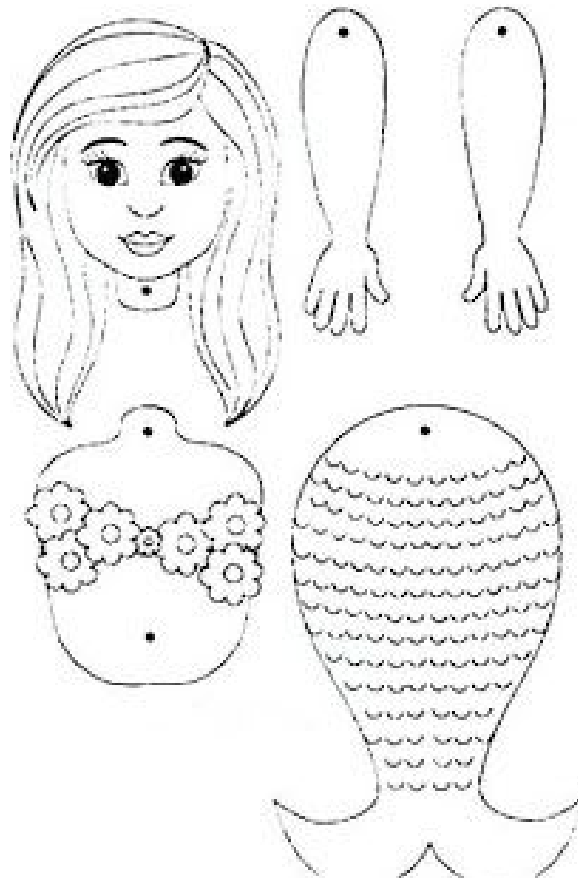

FOLHA EXTRA PARA COLAGEM DA IARA

E. M. "PROF. CALIL RAHAL NETO".

NOME: _____

PROFESSORA: SIMONE

TURMA: 1º ANO A

DATA: 25/08/2021



**ATIVIDADE 2:
MATEMÁTICA
GRÁFICO**

CONTE OS PERSONAGENS DO QUADRO E PINTE UM QUADRADINHO PARA CADA NO GRÁFICO ABAIXO:

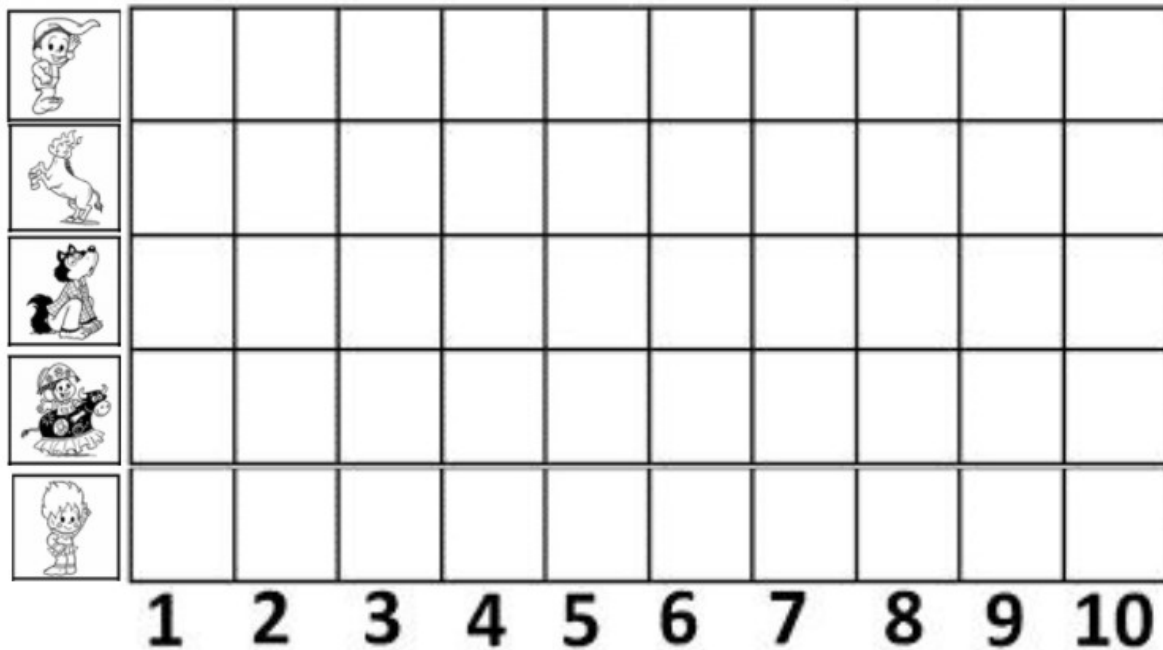

E. M. "PROF. CALIL RAHAL NETO".

NOME: _____

PROFESSORA: SIMONE TURMA: 1º ANO A DATA: 26/08/2021



**ATIVIDADE 1:
LÍNGUA PORTUGUESA**

VAMOS COMPLETAR O NOME DOS PERSONAGENS DO FOLCLORE USANDO SOMENTE AS VOGAIS!



L B S M M



C R P R



C C



B T

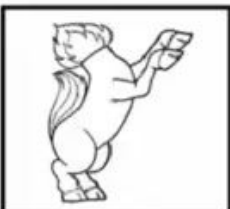

M L



S C



E. M. "PROF. CALIL RAHAL NETO".

NOME: _____

PROFESSORA: SIMONE





TURMA: 1º ANO A

DATA: 26/08/2021

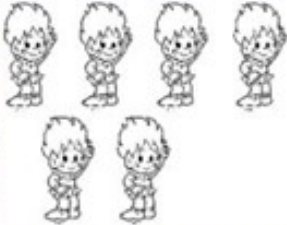
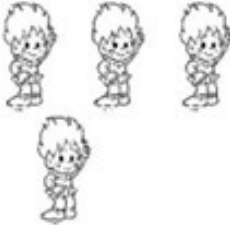

ATIVIDADE 2: MATEMÁTICA

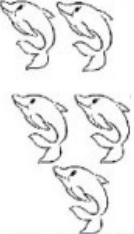
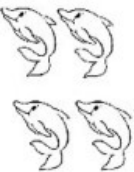
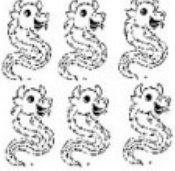
VAMOS SOMAR OS PERSONAGENS FOLCLÓRICOS, COLOCANDO O NÚMERO CORRESPONDENTE ÀS QUANTIDADES CONFORME O EXEMPLO:

HAVIA	CHEGARAM	TOTAL
		10
		
		
		

E. M. "PROF. CALIL RAHAL NETO".

NOME: _____

PROFESSORA: SIMONE TURMA: 1º ANO A DATA: 27/08/2021



ATIVIDADE 1:
LÍNGUA PORTUGUESA
DITADOS POPULARES

OBSERVE AS CENAS E NUMERE
OS DITADOS POPULARES DE
ACORDO COM AS ILUSTRAÇÕES

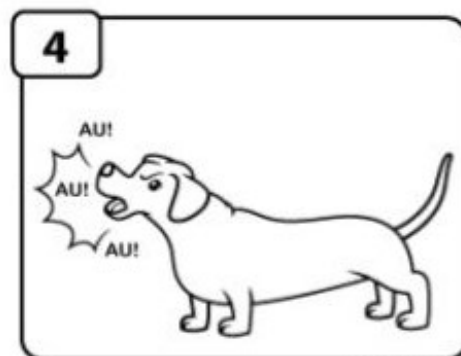
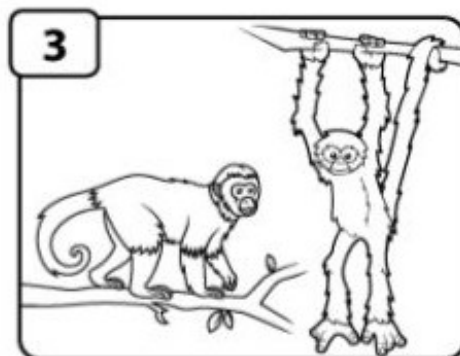
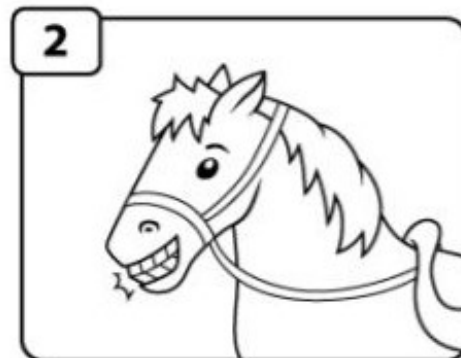
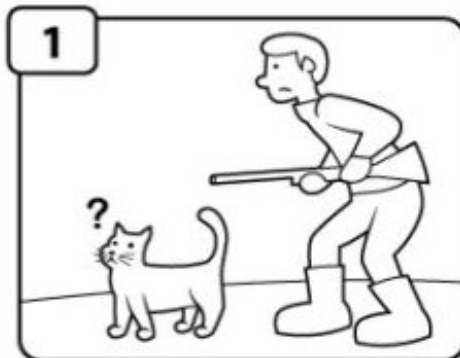

CÃO QUE LATE NÃO MORDE

CAVALO DADO NÃO SE OLHA OS DENTES

QUEM NÃO TEM CÃO CAÇA COM GATO

CADA MACACO NO SEU GALHO

E. M. "PROF. CALIL RAHAL NETO".

NOME: _____

PROFESSORA: SIMONE

TURMA: 1º ANO A

DATA: 27/08/2021



ATIVIDADE 2:

ARTE

PARLENDA: "ERA UMA BRUXA"

ERA UMA BRUXA

À MEIA-NOITE

EM UM CASTELO MAL-ASSOMBRADO

COM UMA FACA NA MÃO

PASSANDO MANTEIGA NO PÃO



ILUSTRE A PARLENDA



REFERÊNCIAS DE PESQUISA

<http://azcolorir.com/desenho/4135>

<https://www.soescola.com/2016/05/atividades-escolares-dia-do-estudante.html>

<https://br.pinterest.com/pin/719168634222115836/>

<https://www.nossoclubinho.com.br/atividades-para-educacao-infantil-dia-do-estudante/>

<https://br.pinterest.com/pin/735564551618602193/>

<https://br.pinterest.com/beatrizamancio94/preven%C3%A7%C3%A3o-de-acidentes-de-tr%C3%A2nsito/>

<https://br.pinterest.com/pin/554153929158267339/>

<https://br.pinterest.com/pin/288230444907319509/>

<https://br.pinterest.com/pin/721631540267711766/>

<https://br.pinterest.com/pin/744853225854986279/>

<https://br.pinterest.com/pin/751186412828942564/>

<https://br.pinterest.com/elisangela6106/folclore/>

<https://br.pinterest.com/pin/751960469015350250/>

https://www.soescola.com/2019/07/caca-palavras-do-folclore.html/caca-palavras-folclore-imprimir#google_vignette

<https://viacarreira.com/atividades-sobre-lendas-folcloricas/>