

E.M ALEXANDRE VANNUCHI LEME

APOSTILA 10

PERÍODO DE 30 DE AGOSTO À 17 DE SETEMBRO



Profª CATARINA SELMA DE OLIVEIRA CEZAR

1º TERMO A

NOME DO ALUNO: _____

TRABALHANDO COM BILHETE

Fábio,
Fui ao mercado comprar
feijão, fubá, farinha, figo e
fósforos. Volto logo.

Um beijo.

Mamãe

01/08/2020

- 1- Quem escreveu o bilhete foi a _____
- 2 – O bilhete era para o _____
- 3- Em que data foi escrito o bilhete ? _____
- 4- A mamãe se despediu com _____
- 5 – A mamãe foi ao _____
- 6 – A mamãe foi comprar _____



Nome: _____

CALCULANDO

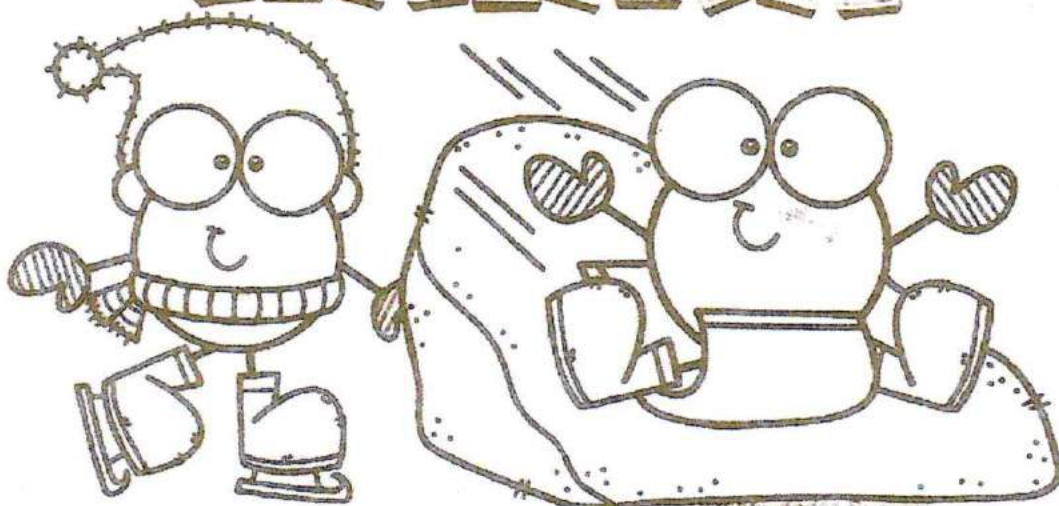

1)
$$\begin{array}{r} 38 \\ - 22 \\ \hline \end{array}$$

2)
$$\begin{array}{r} 36 \\ - 23 \\ \hline \end{array}$$

3)
$$\begin{array}{r} 96 \\ - 53 \\ \hline \end{array}$$

4)
$$\begin{array}{r} 97 \\ - 46 \\ \hline \end{array}$$

5)
$$\begin{array}{r} 83 \\ - 20 \\ \hline \end{array}$$

6)
$$\begin{array}{r} 59 \\ - 21 \\ \hline \end{array}$$

7)
$$\begin{array}{r} 97 \\ - 34 \\ \hline \end{array}$$

8)
$$\begin{array}{r} 97 \\ - 64 \\ \hline \end{array}$$

9)
$$\begin{array}{r} 27 \\ - 12 \\ \hline \end{array}$$

10)
$$\begin{array}{r} 61 \\ - 10 \\ \hline \end{array}$$

11)
$$\begin{array}{r} 67 \\ - 26 \\ \hline \end{array}$$

12)
$$\begin{array}{r} 95 \\ - 32 \\ \hline \end{array}$$

13)
$$\begin{array}{r} 67 \\ - 55 \\ \hline \end{array}$$

14)
$$\begin{array}{r} 88 \\ - 53 \\ \hline \end{array}$$

15)
$$\begin{array}{r} 89 \\ - 13 \\ \hline \end{array}$$

16)
$$\begin{array}{r} 82 \\ - 11 \\ \hline \end{array}$$

17)
$$\begin{array}{r} 98 \\ - 12 \\ \hline \end{array}$$

18)
$$\begin{array}{r} 86 \\ - 61 \\ \hline \end{array}$$

19)
$$\begin{array}{r} 98 \\ - 76 \\ \hline \end{array}$$

20)
$$\begin{array}{r} 54 \\ - 20 \\ \hline \end{array}$$



NOME: _____ Nº _____

SALA: _____ PROFª _____ TURMA: _____



Matemática

Resolva

$$\begin{array}{r} 63 \\ + 3 \\ \hline \end{array}$$

$$\begin{array}{r} 92 \\ + 5 \\ \hline \end{array}$$

$$\begin{array}{r} 48 \\ + 2 \\ \hline \end{array}$$

$$\begin{array}{r} 26 \\ + 6 \\ \hline \end{array}$$

$$\begin{array}{r} 95 \\ + 2 \\ \hline \end{array}$$

$$\begin{array}{r} 93 \\ + 3 \\ \hline \end{array}$$

$$\begin{array}{r} 67 \\ + 6 \\ \hline \end{array}$$

$$\begin{array}{r} 45 \\ + 6 \\ \hline \end{array}$$

$$\begin{array}{r} 38 \\ + 4 \\ \hline \end{array}$$

$$\begin{array}{r} 63 \\ + 7 \\ \hline \end{array}$$

$$\begin{array}{r} 74 \\ + 7 \\ \hline \end{array}$$

$$\begin{array}{r} 23 \\ + 5 \\ \hline \end{array}$$

$$\begin{array}{r} 88 \\ + 89 \\ \hline \end{array}$$

$$\begin{array}{r} 72 \\ + 43 \\ \hline \end{array}$$

$$\begin{array}{r} 42 \\ + 29 \\ \hline \end{array}$$

$$\begin{array}{r} 92 \\ + 98 \\ \hline \end{array}$$



CAÇANDO ANIMAIS

1. Encontre, no caça-palavras abaixo, o nome dos animais em destaque

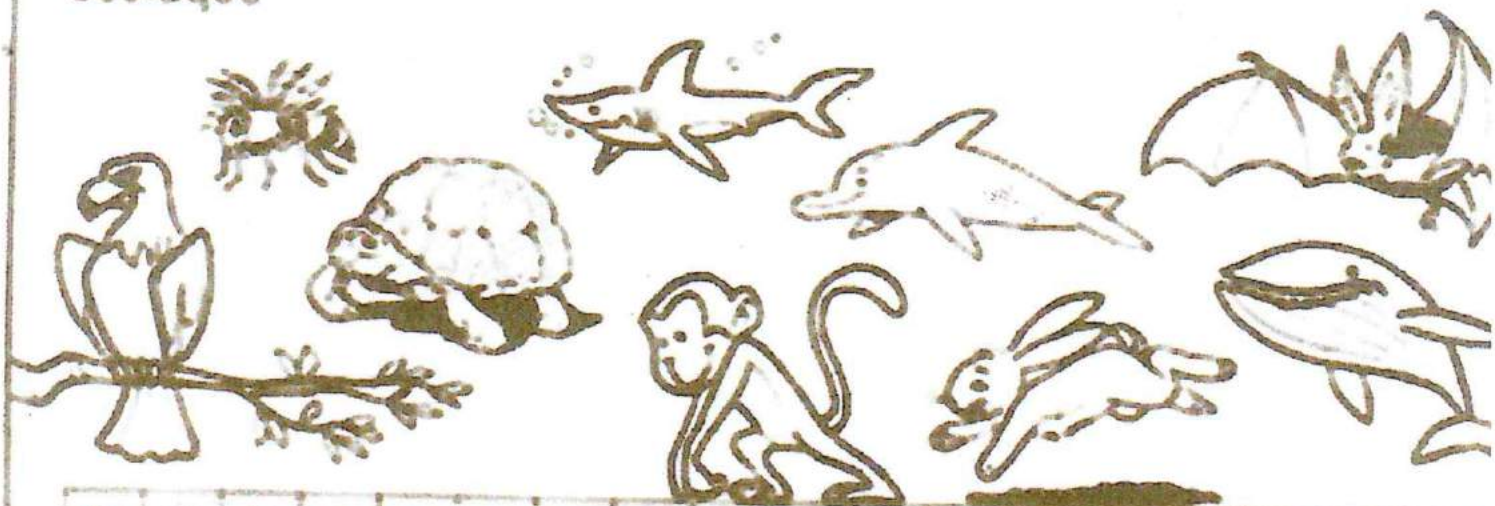

M	O	R	C	E	G	O	Q	K	A	B	E	L	H	A	D	N	P
D	S	C	O	E	L	H	O	V	L	R	G	A	V	I	Ã	O	M
P	C	M	A	C	A	C	O	F	G	H	M	B	A	L	E	I	A
T	U	B	A	R	Ã	O	F	P	R	J	A	B	U	T	I	N	S
C	L	F	N	G	O	L	F	I	N	H	O	V	B	D	W	K	J

2. Agora, escreva os nomes dos animais nos quadros correspondente

Animais aquáticos	Animais terrestres	Animais voadores
BALEIA		MORCEGO

ESCRITA ORIENTADA









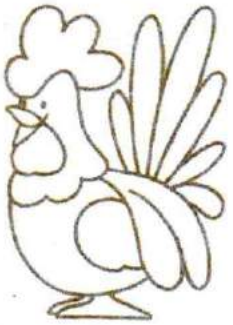

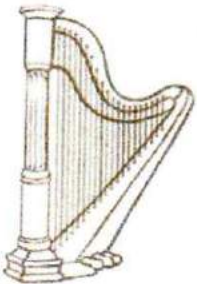

HARPA

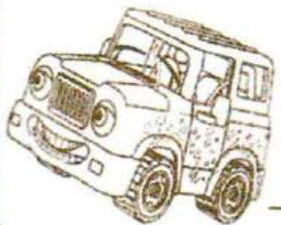

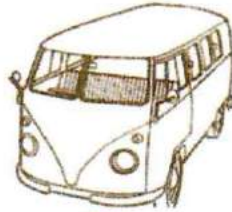



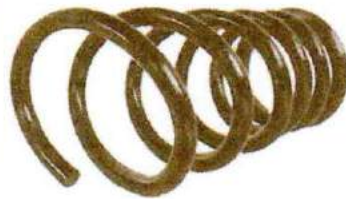

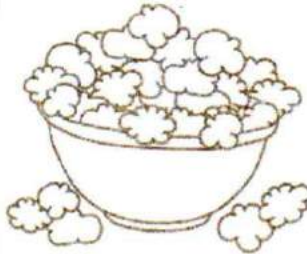

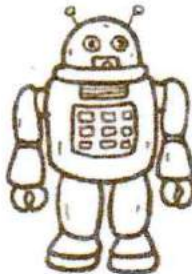



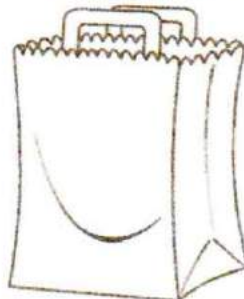

PEQUENOS GRANDES PENSANTES



ESCRITA ORIENTADA

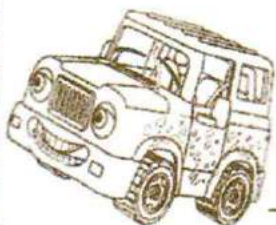
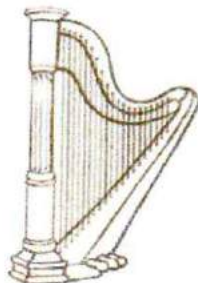

HARPA

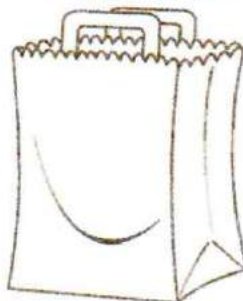
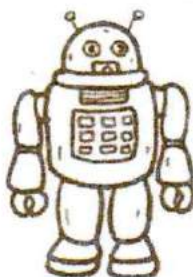
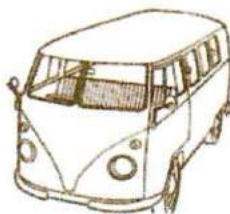

PEQUENOS GRANDES PENSANTES



Escola:

Data: Turma:

Aluno:

ATIVIDADES

HINO DA INDEPENDÊNCIA DO BRASIL

TRECHO DA MÚSICA DE EVARISTO DA VEIGA

LETRA DE D. PEDRO I

JÁ PODEIS, DA PÁTRIA FILHOS,
VER CONTENTE A MÃE GENTIL;
JÁ RAIOU A LIBERDADE
NO HORIZONTE DO BRASIL.



BRAVA GENTE BRASILEIRA!
LONGE VÁ... TEMOR SERVIL:
OU FICAR A PÁTRIA LIVRE
OU MORRER PELO BRASIL.

1. Vamos encontrar as palavras sublinhadas!

W	E	P	Á	T	R	I	A	R	T	Y	U	I
L	I	B	E	R	D	A	D	E	P	A	S	D
G	H	O	R	I	Z	O	N	T	E	H	J	K
Z	X	B	R	A	S	I	L	E	I	R	A	X
V	B	N	M	L	I	V	R	E	Q	A	Z	W
X	B	R	A	S	I	L	E	D	C	R	F	V

LEIA ATENTAMENTE E RESPONDA:

PERDEU-SE:

Gratifica-se bem a quem encontrar?

Espuminha

Cadela Poodle cinza, muito querida por três crianças.

Favor entrar em contato com Paola

Telefone: 200-5356



1) DE QUE SE TRATA O ANÚNCIO?

2) QUAL O NOME DA CADELINHA?

3) QUEM COLOCOU O ANÚNCIO?

4) QUAL A DESCRIÇÃO DA CADELINHA?

CAÇA-PALAVRAS

NH

Q	A	R	A	N	H	A	Q	W	E	R	T	M
W	A	S	P	I	N	T	I	N	H	O	D	I
C	E	G	O	N	H	A	F	G	H	J	K	N
E	Z	X	C	V	B	N	M	L	K	J	H	H
R	G	Z	R	Q	W	N	I	N	H	O	L	O
T	A	X	A	A	S	D	F	G	H	J	K	C
Y	L	C	I	Z	V	L	I	N	H	A	D	A
U	I	V	N	X	C	V	B	N	M	L	C	J
I	N	B	H	C	C	A	M	I	N	H	A	O
O	H	N	A	Z	X	C	V	B	N	M	L	J
P	A	M	W	D	I	N	H	E	I	R	O	G
A	H	L	A	S	D	F	G	H	J	K	L	M
J	O	A	N	I	N	H	A	V	B	N	M	K
S	J	K	I	G	O	L	F	I	N	H	O	O

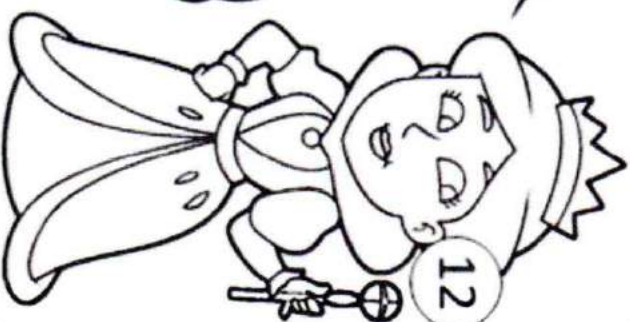
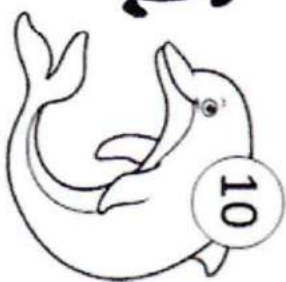
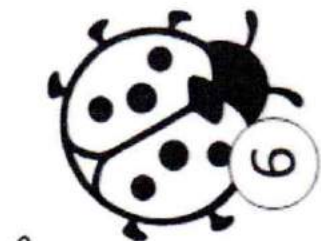
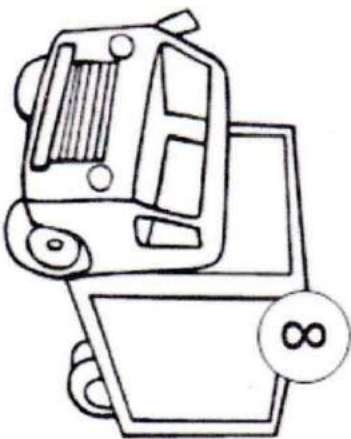
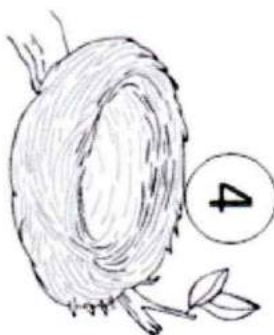
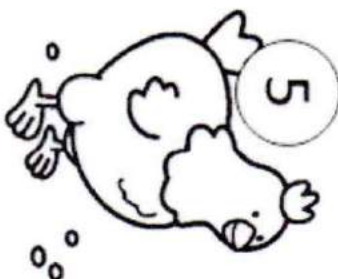
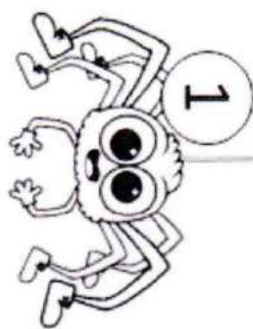

LIGUE OS NOMES AOS DESENHOS. DEPOIS, ESCREVA E SEPRE AS PALAVRAS EM SÍLABAS.



- VINHO
- SARDINHA
- MINHOCA
- GAFANHOTO
- PINHEIRO
- ARANHA
- NINHO
- GALINHA

VI	NHO

ESCREVA AS PALAVRAS NO DOMINOX, PORÉM SEPARANDO-AS EM SÍLABAS.

- ARANHA
- NINHO
- GATINHO
- MINHOCA
- SARDINHA
- PAMONHA
- NENHUM
- GAFANHOTO
- CAMINHÃO
- NHOQUE

	A	RA	NHA

NUMERANDO AS PLACAS DE TRÂNSITO



1



2



3



4



5



6



7



8

NUMERE AS PLACAS DE ACORDO COM O SIGNIFICADO DE CADA UMA.



PARADA OBRIGATÓRIA



PROIBIDO O TRÂNSITO DE BICICLETAS



PROIBIDO ULTRAPASSAR



PROIBIDO ESTACIONAR



ÁREA ESCOLAR



CRIANÇAS



CUIDADO! ANIMAIS



PROIBIDO O TRÂNSITO DE PEDESTRE

Já sei 😊

Tenho que praticar. 😐

Ainda não sei. 😞

Nome _____ Data ____/____/____

Números de 1 até ao 200

 **Completa a tabela.**

1		3		5		7		9
	12		14		16		18	20
21		23		25		27		29
	32		34		36		38	40
41		43		45		47		49
	52		54		56		58	60
61		63		65		67		69
	72		74		76		78	80
81		83		85		87		89
	92		94		96		98	100
101		103		105		107		109
	112		114		116		118	120
121		123		125		127		129
	132		134		136		138	140
141		143		145		147		149
	152		154		156		158	160
161		163		165		167		169
	172		174		176		178	180
181		183		185		187		189
	192		194		196		198	200

 **Completa a sequência.**

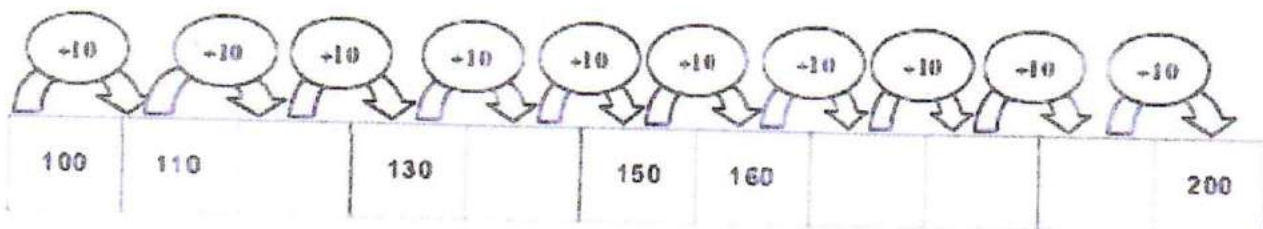

TRABALHANDO COM TIRINHAS



1- Este gênero textual é:

- | | |
|----------------------------------|----------------------------------|
| <input type="checkbox"/> carta | <input type="checkbox"/> tirinha |
| <input type="checkbox"/> receita | <input type="checkbox"/> fábula |

2- Onde acontece a cena em que o Chico Bento está?

- | | |
|--|--|
| <input type="checkbox"/> Na esquina da rua | <input type="checkbox"/> Numa pracinha |
| <input type="checkbox"/> Dentro de casa | <input type="checkbox"/> Num sítio |

3- O animal que está em questão neste diálogo é o

- | | | |
|---------------------------------|------------------------------|---------------------------------|
| <input type="checkbox"/> macaco | <input type="checkbox"/> boi | <input type="checkbox"/> cavalo |
|---------------------------------|------------------------------|---------------------------------|

4- O assunto principal do texto é:

- | |
|---|
| <input type="checkbox"/> um passeio no sítio. |
| <input type="checkbox"/> falta de conhecimento sobre o assunto de gado. |
| <input type="checkbox"/> boi sem cabeça. |
| <input type="checkbox"/> o exibimento do menino. |

Escola

Data Turma LETY ORZINI O. S OMI

Aluno

Encontre o nome dos solidos geométricos no caça-palavras

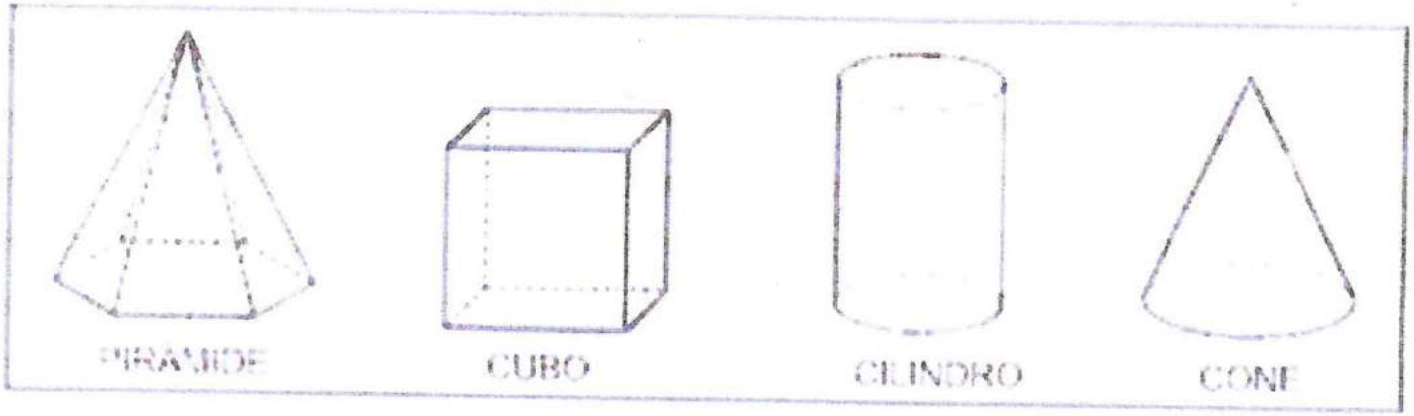

P	I	R	Â	M	I	D	E
C	R	A	H	M	A	Â	Ç
I	Ç	R	C	O	S	T	O
L	L	P	C	V	A	B	N
I	O	X	C	U	B	O	J
N	G	G	R	Â	M	E	O
D	Ç	C	U	B	A	Z	N
R	I	R	O	Â	G	E	H
O	E	R	V	C	O	N	E

Referência Setembro Eja

<https://i2.wp.com/miriamveiga.com.br/wp-content/uploads/2030/07/03.09-bilhete-interpreta%C3%A7%C3%A3o.jpg>

<https://alfakids.org/atividades-de-matematica-subtracao-divertida/>

<http://continhasfundamentais.blogspot.com/2018/06/continhas-de-adicao-e-subtracao-copa-do.html>

<https://br.pinterest.com/pin/823173638112332387/>

<https://br.pinterest.com/pin/257620041164325029/>

<https://lereaprender.com.br/atividades-sobre-a-independencia-do-brasil/hino-da-independencia-do-brasil/>

<https://educacaoetransformacaooficial.blogspot.com/2018/10/apostila-anuncios-e-propagandas.html>

<https://br.pinterest.com/pin/673991900464357209/>

<https://br.pinterest.com/pin/623537510899550825/>

<https://br.pinterest.com/pin/756464068637366490/>

<https://www.atividadesmatematica.com/2017/05/atividades-com-numeros-de-100-500.html>

<https://br.pinterest.com/anamariahedy/trabalho-com-tirinhas/>

<https://br.pinterest.com/pin/728738783441212375/>

<https://www.liveworksheets.com/gd1814458zn>